

CHEMISTRY PROGRESS

Majalah Publikasi Ilmu Kimia

Volume 3, Nomor 1
Mai 2010

ISSN : 1979-5920

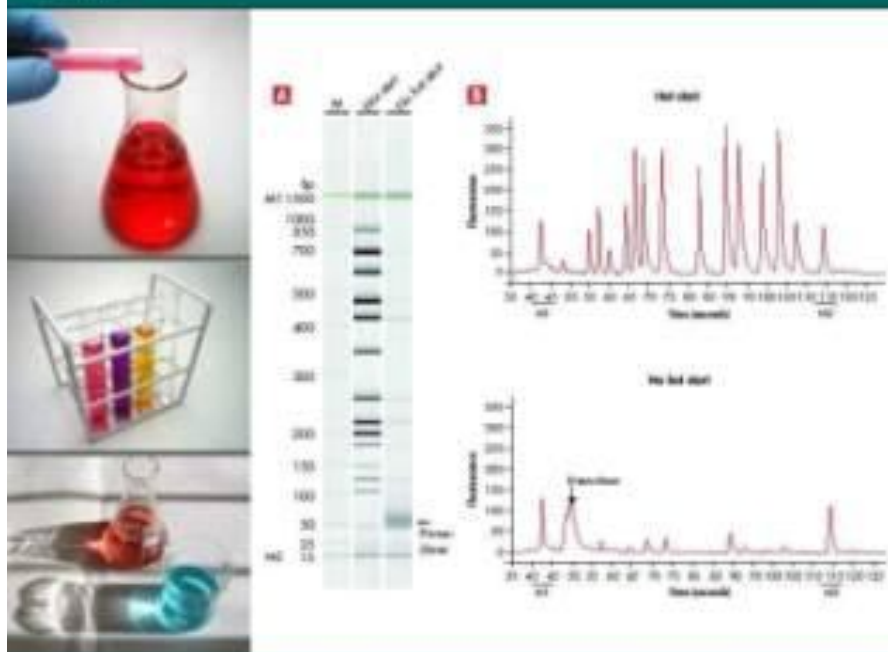

Chem.Prog

Vol. 3

No. 1

Hal. 1-56

Majalah, Mei 2010

ISSN: 1979-5920

Ditubuhkan Oleh:

JURUSAN FISIKA

FACULTAS MATEMATIKA DAN ILMU PENGETAHUAN ALAM

UNIVERSITAS SAM RATULANGI

Artikel dapat dicermati selengkapnya pada web jurnal Chemistry Progress (<http://ejournal.unsrat.ac.id/index.php/chemprog/issue/archive>)

ISSN: 1979-5920

CHEMISTRY PROGRESS

Majalah Ilmiah Chemistry Progress merupakan media untuk menyebarkan informasi ilmiah dan sarana komunikasi bagi para ilmuan dan cendekiawan melalui tulisan-tulisan ilmiah. Majalah Ilmiah Chemistry Progress terbit pertama kali tahun 2008 dengan frekuensi dua nomor dalam satu tahun (Mei dan November) berisi kajian penelitian dalam lingkup ilmu kimia (organik, anorganik, analitik, biokimia, fisika, bahan alam, lingkungan, pangan, kelautan, pertambangan, farmasi dan komputasi).

Ketua Penyunting

Edi Suryanto

Wakil Ketua Penyunting

Frenly Wehantouw

Penyunting Pelaksana

Audy Wuntu
Harry Kolcangan
Maureen Kumaunang
Mariska Pitoi

Produksi dan Distribusi

Vanda S. Kamu

Percetakan

Sam Ratulangi Press, Manado

Ist diluar tanggungjawab percetakan

Alamat Redaksi :

Jl. Kampus UNSRAT Kleak Manado, Sulawesi Utara. Kode Pos : 95115

Telp. (0431) 827964, 085256311981, Fax. (0431) 827964.,

Email: chemistryprogress@yahoo.com

Website: <http://ejournal.unsrat.ac.id/index.php/chemprog>

PENERBIT

Jurusan Kimia, Fakultas Matematika Dan Ilmu Pengetahuan Alam,

Universitas Sam Ratulangi

Himpunan Kimia Indonesia Cabang Sulawesi Utara

Screen Capture web yang memuat daftar isi makalah yang dimuat dalam vol. 7 no. 1

(<http://ejournal.unsrat.ac.id/index.php/chemprog/about/editorialTeam>)

CHEMISTRY PROGRESS

USER

Username

Password

Remember me

JOURNAL CONTENT

Search

All

How we

- [By Issue](#)
- [By Author](#)
- [By Title](#)
- [Other Journals](#)

[HOME](#) [ABOUT](#) [LOG IN](#) [SEARCH](#) [CURRENT](#) [ARCHIVES](#) [WEBSITE UNSRAI](#)

[WEBMAIL UNSRAI](#) [PORTAL AKADEMIK](#) [PORTAL E-JOURNAL](#) [REPOSITORY UNSRAI](#)

[Home](#) > [About the Journal](#) > [Editorial Team](#)

EDITORIAL TEAM

PENANGGUNG JAWAB

Prof. dr. Edwin de Queljoe, Universitas Sam Ratulangi, Indonesia

KETUA REDAKSI

Prof. Dr. Edi Suryanto, Universitas Sam Ratulangi, Indonesia

SEKRETARIS

Ir. Andy Wuntu, Universitas Sam Ratulangi, Indonesia
Frenly Wehantoura, Universitas Sam Ratulangi, Indonesia

BENDAHARA

Johany A. Korong, Universitas Sam Ratulangi, Indonesia

DEWAN REDAKSI

Dra. Meiske Sangi, Universitas Sam Ratulangi, Indonesia
Lidya Momuat, Universitas Sam Ratulangi, Indonesia
Drs. Herling Banghunan, Universitas Sam Ratulangi, Indonesia
Dewa G. Katja, Universitas Sam Ratulangi, Indonesia
Henry Aritonang, Universitas Sam Ratulangi, Indonesia
Ir. Harry Koleangan, Universitas Sam Ratulangi, Indonesia
Drs. Jemmy Abidjubi, Universitas Sam Ratulangi, Indonesia
Maureen Kumamang, Universitas Sam Ratulangi, Indonesia

VOL 7, NO 1 (2014)

TABLE OF CONTENTS

ARTICLES

- | | |
|---|-----|
| Catalytic activity test of Mo-V-Te-Nb-Oxide in ammoxidation of propane to acrylonitrile
<i>Restu Kartiko Widi</i> | PDF |
| Analisis kapasitas tukar kation birnessite
<i>Pepi Helza Yanti</i> | PDF |
| Fotokatalis TiO ₂ -zeolit untuk degradasi metilen biru
<i>Nevi Dwi Andari</i> | PDF |
| Efisiensi dan karakterisasi komposit karboksimetil kitosan dan fraksi amilosa sebagai inhibitor korosi pada permukaan baja lunak dalam media HCl 1 M
<i>Maria Erna</i> | PDF |
| Pembuatan tes kit kertas nitrogen-amonia berdasarkan pembentukan senyawa indofenol biru
<i>Hermin Sulistyarti</i> | PDF |
| Kajian Proses Produksi Garam Aneka Pangan Menggunakan Beberapa Sumber Bahan Baku
<i>Eriawan Rismana</i> | PDF |
| Degradasi metilen blue menggunakan fotokatalis ZnO-zeolit
<i>Eka Wahyu Putri Dini</i> | PDF |
| Korelasi fenolat total dan flavonoid total dengan antioksidan dari beberapa sediaan ekstrak buah tanjung (<i>Mimusops elengi</i>)
<i>Cahaya Perwiratami</i> | PDF |

Screen Capture web yang memuat abstract article dalam
(<http://ejournal.unsrat.ac.id/index.php/chemprog/article/view/4846>)

CHEMISTRY PROGRESS

USER

Username
Password
 Remember me

[HOME](#) [ABOUT](#) [LOG IN](#) [SEARCH](#) [CURRENT](#) [ARCHIVES](#)
[WEB SITE UNSRAT](#) [WEBMAIL UNSRAT](#) [PORTAL AKADEMIK](#) [PORTAL](#)
[E-JOURNAL](#) [REPOSITORY UNSRAT](#)

Home > Vol 7, No 1 (2014) > Widi

JOURNAL CONTENT

Search

All

Browse
[By Issue](#)
[By Author](#)
[By Title](#)
[Other Journals](#)

CATALYTIC ACTIVITY TEST OF MO-V-TE-NB-OXIDE IN AMMOXIDATION OF PROPANE TO ACRYLONITRILE

Restu Kariko Widi

ABSTRACT

The ammoxidation of propane has been investigated at a multicomponent oxidic, MoVTeNb catalyst in the temperature of 673 K. The catalyst was prepared by sol-gel method, and dried by spray dried method. The activity test of the catalyst has been carried out using micro reactor and showed that it was active for ammoxidation of propane to acrylonitrile.

Keywords : ammoxidation, propane, mixed metal oxide catalyst, acrylonitrile

Screen Capture web yang memuat article dalam format PDF
(<http://ejournal.unsrat.ac.id/index.php/chemprog/article/view/4846/4371>)

CHEMISTRY PROGRESS

USER
Username
Password
 Remember me

HOME ABOUT LOGIN SEARCH CURRENT ARCHIVES WEBSITE
UNSRAT WEBMAIL UNSRAT PORTAL AKADEMIK PORTAL E-JOURNAL
REPOSITORY UNSRAT

Home > Vol 7, No 1 (2014) > Widi

JOURNAL CONTENT
Search
All
Browse
By Issue
By Author
By Title
Other Journals

Laman: 1 dari 4 Perbesaran Otomatis

CATALYTIC ACTIVITY TEST OF Mo-V-Te-Nb-OXIDE IN AMMOXIDATION OF PROPANE TO ACRYLONITRILE

Estu Kartika Widi
*Department of Chemical Engineering,
University of Surabaya*

ABSTRAK

Widi, R. K., 2014. Catalytic activity test of Mo-V-Te-Nb-Oxide in ammoxidation of propane to acrylonitrile.

The ammoxidation of propane has been investigated at a multicomponent oxide, MoVTeNb oxide at the temperature of 873 K. The catalyst was prepared by sol-gel method, and dried by spray dried method. The activity test of the catalyst has been carried out using micro reactor and showed that it was active for ammoxidation of propane to acrylonitrile.

Keywords: ammoxidation, propane, mixed metal oxide catalyst, acrylonitrile

ABSTRACT

Widi, R. K., 2014. Uji aktivitas katalisis Mo-V-Te-Nb-Oxide pada ammoxidasi propane menjadi acrylonitril

The ammoxidation of propane has been investigated at a multicomponent oxide, MoVTeNb oxide at the temperature of 873 K. The catalyst was prepared by sol-gel method, and dried by spray dried method. The activity test of the catalyst has been carried out using micro reactor and showed that it was active for ammoxidation of propane to acrylonitrile.

Keywords: ammoxidation, propane, mixed metal oxide catalyst, acrylonitrile

INTRODUCTION

Selective catalytic oxidation and ammoxidation of hydrocarbon comprise approximately 60% of the process of hydrocarbon conversion (Mason et al. 2000). Oxid catalyst was studied by Ullrich et (Mason et al. 2000).

CATALYTIC ACTIVITY TEST OF Mo-V-Te-Nb-OXIDE IN AMMOXIDATION OF PROPANE TO ACRYLONITRILE

Restu Kartiko Widi¹

¹ *Department of Chemical Engineering,
University of Surabaya*

ABSTRAK

Widi, R. K. 2014. Catalytic activity test of Mo-V-Te-Nb-Oxide in ammoxidation of propane to acrylonitrile

The ammoxidation of propane has been investigated at a multicomponent oxidic, MoVTeNb catalyst in the temperature of 673 K. The catalyst was prepared by sol-gel method, and dried by spray dried method. The activity test of the catalyst has been carried out using micro reactor and showed that it was active for ammoxidation of propane to acrylonitrile.

Kata kunci : ammoxidation, propane, mixed metal oxide catalyst, acrylonitrile

ABSTRACT

Widi, R. K. 2014. Uji aktivitas katalisis Mo-V-Te-Nb-Oxide pada ammoksidasi propana menjadi akrilonitril

The ammoxidation of propane has been investigated at a multicomponent oxidic, MoVTeNb catalyst in the temperature of 673 K. The catalyst was prepared by sol-gel method, and dried by spray dried method. The activity test of the catalyst has been carried out using micro reactor and showed that it was active for ammoxidation of propane to acrylonitrile.

Keywords : ammoxidation, propane, mixed metal oxide catalyst, acrylonitrile

INTRODUCTION

Selective catalytic oxidation and ammoxidation processes of hydrocarbons comprise approximately one quarter of the value produced by all catalytic processes world wide. They contribute hence significantly to the gross national product of industrial countries and afford future opportunities for developing countries. These processes are not only important from a commercial standpoint and their contribution to the well-being of modern mankind, but they also present the opportunity for significant fundamental research. Such research aims at the molecular level understanding of catalytic behaviour, forming a basis for rational design of catalyst improvement of existing processes and the discovery of totally new catalysts and processes (Betahar et al., 1996).

The selective oxidation of lower alkanes to various functionalized molecules has attracted much interest in recent years. Propane partial oxidation to acrylic acid over vanadium pyrophosphate (VPO) catalysts has been reported. Propane oxidation to acrylic acid with heteropolyacids or with their corresponding salts has also been reported. In propane ammoxidation to acrylonitrile, V-Sb oxide catalysts were studied by several researchers and Mo-V-Te-Nb-

oxide catalysts were studied by Ushikubo et al. (Manhua et al., 2000).

This paper limits itself to the activity test of diluted Mo-V-Te-Nb-oxide catalyst for propane ammoxidation processes.

MATERIALS AND METHODS

Catalyst preparation

Preparation of solution 1 (Mo-V-Te)

Eleven point two and seven grams of AHM was dissolved in 100 ml of water. This solution was heated up to 353 K. A clear solution was obtained from AHM. This solution was stirred at a speed of 700 rpm. After complete dissolution of the solid, 2.24 g of AMV was added, and 3.37 g of Telluric acid was added after the AMV had dissolved completely.

Preparation of solution 2 (Nb)

Three point five and four grams of Niobium ammonium oxalate was dissolved in 29 ml of water. This solution was stirred until all solids had dissolved without heating. Solution 1 was heated up to a

temperature of 353 K, and then cooled down to ~313 K. 14.36 g of Aerosil300 was added slowly to the solution. Then Solution 2 was mixed with Solution 1. The mixture yielded an orange gel which was stirred for 10 minute before the product was transferred into a spray dryer. 20.8 g of the orange fine product was collected.

Activation

The dried material was precalcined from room temperature to 598 K at a rate of 10 K/min in air (100 ml/min) for 1 h and then calcined from room temperature to 923 K at a rate of 2 K/min in helium (100 ml/min) for 2 h.

Catalytic activity test

Approximately 10 g of catalyst was packed in an 12 mm ID stainless steel tubular reactor and tested at 673 K at a propane/O₂/He/NH₃ mole ratio of 1/3/18/3, a space velocity of 1200 h⁻¹ and a pressure of 1 atm. The product streams were analyzed by gas chromatography (GC) by means Agilent.

RESULT AND DISCUSSION

Acrylonitrile (ACN) is an important intermediates in petrochemistry and exhibit excellent annual growth; the main application includes synthetic fibers and resins. For decades, the ammoxidation of propylene to acrylonitrile is the most important process whereby more than 5 billion kg/year of acrylonitrile (with growth rate of 4% per year) are produced worldwide via the SOHIO/BP process. The said process is very efficient, fully converting propylene at the same time giving > 80% acrylonitrile yield on commercial scale.

The chemical equation of the SOHIO/BP process as extracted from literature (Olga et al., 2004) is given as follow:-

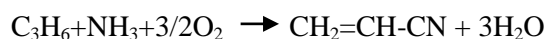

Catalyst: (K,CS)_{0.1-0.2}, Ni,Co,Mn,Mg)_{7.5-9.5}, (Fe,Cr)_{2.3-2.5}, Bi_{0.5-1.0}, Mo₁₂O_x/SiO₂ (MCM)

Despite the efficiency of the process, the price of propylene has seen attention being drawn to develop a method for producing acrylonitrile by ammoxidation reaction whereby lower alkane such as propane is used as a starting material *i.e.* propane catalytically reacted with ammonia and oxygen in a gaseous phase in the presence of a catalyst. Beside the economical factor of propane being a cheaper and more abundant feed, ammoxidation of propane is also a less energy intensive process. As such, promising acrylonitrile yield above 58% have already been obtained from propane using a patented Mo-V-Nb-Te-O_x catalyst developed by Mistsubishi Chemical Company (Olga et al., 2004).

Future Process utilizing propane as starting material:-



Mo-V-Te-Nb mixed oxides is an interesting developing catalyst in the transformation of short-chain alkanes, *i.e.* C1-C4. It has been known that acrylonitrile (ACN) and acrylic acid (AA) can *selectively* be obtained in the ammoxidation and the oxidation of propane. Observation made based on the previous work of Olga et al. (2004) found that the best catalysts (V-Sb-Al) for ammoxidation are those exhibited the lowest yield in the oxidation process to acrylic acid and vice versa. The fact that Mo-V-Te-Nb-oxides could be used in both ammoxidation and/or oxidation underlines the advantage of this new multi-mixed oxide catalyst as compared to conventional catalysts such as Sb-containing material (V-Sb-Al, Mo-V-Sb-O_x, etc.) (Hinago & Komada, 2000).

The formation of acrylonitrile (ACN) also strongly depends on the presence of ammonia. The proportion of ammonia to be supplied for the reaction is preferably within a range of from 0.2 to 5 moles, particularly from 0.5-3 moles, per mol of propane (Ushikubo, 1995)

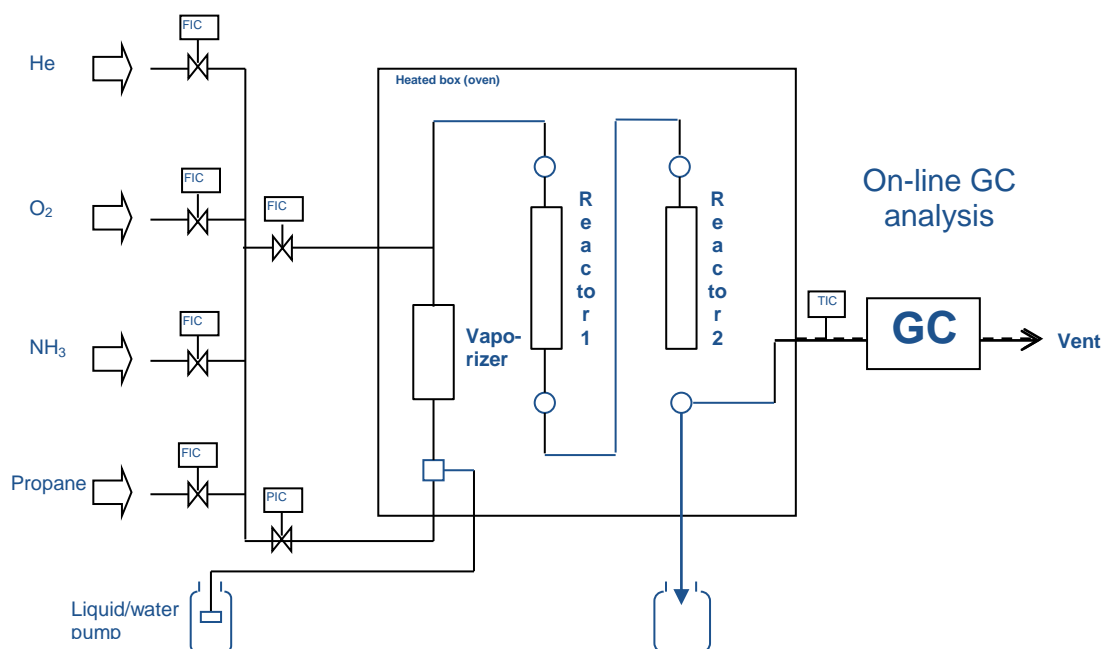

Figure 1. The schematic diagram of the reactor for ammoxidation of propane

In the absence of ammonia, only acrylic acid is obtained over Mo-V-Te-Nb catalyst [5]. The incorporation of ammonia using the same catalyst increases both the propane conversion and the selectivity to ACN although the catalytic results depend strongly on the $\text{NH}_3 / \text{C}_3\text{H}_8$ ratio. Therefore, *caution* need to be taken to juggle the proportion of feeds used, i.e. propane/oxygen (air)/ ammonia. In too excess of oxygen, higher conversion of propane as a

trade off to the selectivity of nitriles may be obtained. On the other hand, the use of the right $\text{NH}_3/\text{C}_3\text{H}_8$ ratios may be in favors to an important decrease in propane conversion and at the same time increase in the selectivity to ACN.

The activity test of Mo-V-Te-Nb-oxide catalyst from this study using the reactor (figure 1) is shown below (figure 2);

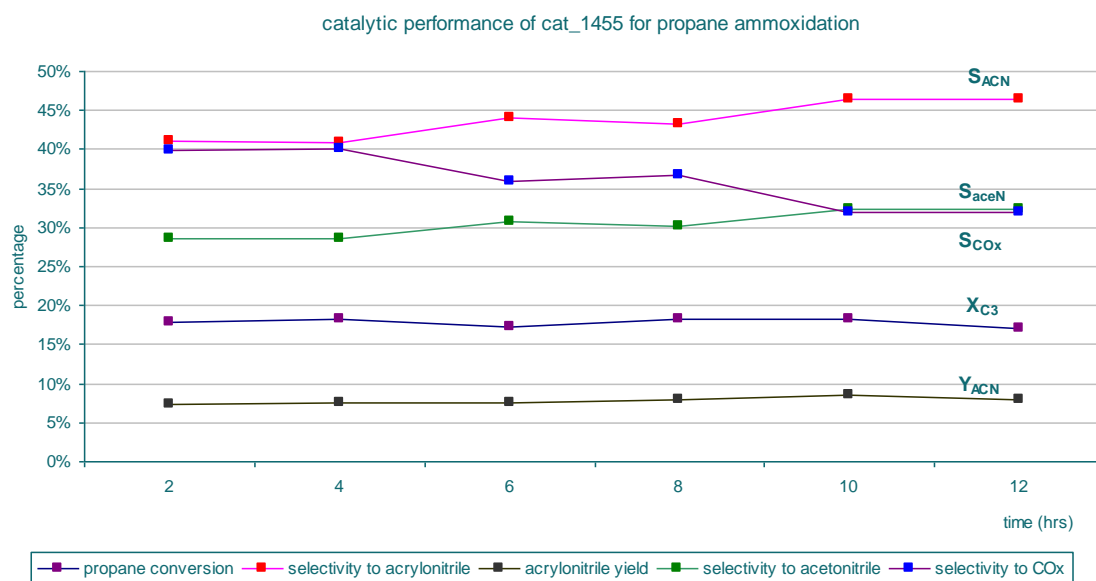

Figure 2. Catalytic Performance for Propane Ammoxidation Using Petrochemical Reactor

Figure 2 describes that the Mo-V-Te-Nb-oxide catalyst used for this reaction is active for ammoxidation of propane to acrylonitrile. The conversion of propane is about 18% and the selectivity to acrylonitrile is slightly increased from about 42% to 47% during the reaction. This indicates that the catalyst is active until 12 hours reaction. It might be still active even if the reaction is carried out for longer time. The potential of this catalyst for propane ammoxidation need to improve, since the product stream still contains CO_x (CO₂ and CO) in quite high amount. There are some suggestions to improve the catalytic performance of this catalyst, i.e. improve the drying process, improve the calcinations process, or improve the reaction condition of propane ammoxidation.

CONCLUSIONS

Based on the result, it can be concluded that Mo-V-Te-Nb-oxide catalyst is an active catalyst for ammoxidation of propane to acrylonitrile. The formation of acrylonitrile (ACN) strongly depends on the presence of ammonia..

ACKNOWLEDGMENT

This research has been carried out in the COMBICAT Laboratory, University of Malaya Kuala Lumpur, Malaysia.

REFERENCES

- Betahar, M. M., Costentin, G., Savary, L. & J.C. Lavalley. 1996. *On the partial oxidation of propane and propylene on mixed metal oxide catalysts. Applied Catalysis A: General* 145, p. 1-48
- Hinago, H. & S. Komada. 2000. *Ammoxidation catalyst for use in producing acrylonitrile or methacrylonitrile from propane or isobutane by ammoxidation, US Patent 6,063,728.*
- Manhua, L., Tejal, B., Desi., Frederick, W., Kaiser & P. D. Klugherz. 2000. Reaction pathways in the selective oxidation of propane over a mixed metal oxide catalyst *Catalyst Today* 61 (1-4), p 223-229
- Olga, M. G. P., Jamal, N. A., Vadim V. G. & A. B. Miguel. 2004. *Catalytic properties of mixed Mo-V-Sb-Nb-O oxides catalysts for the ammoxidation of propane to acrylonitrile, Applied Catalysis A: General* 260 (1), p.93-99
- Ushikubo, T., Oshima, K., Kayo, A., Umezawa, T., Kiyono, K., Sawaki, I. & H. Nakamura. 1995. *Catalyst for the production of nitriles, US Patent 5,472,925.*