



# The Application of the Box-Jenkins (BJ) Method for Process Identification of the Batch Milk Cooling System

Rudy Agustriyanto<sup>1</sup>, P. Setyoprato<sup>1</sup> and E. Srihari Mochni<sup>1</sup>

<sup>1</sup> Chemical Engineering Department, University of Surabaya, Surabaya 60293, Indonesia  
rudy.agustriyanto@staff.ubaya.ac.id

**Abstract.** The Box-Jenkins (BJ) method is a well-known system identification method that has been applied in several fields. Engineers use the Box-Jenkins method for quality control and process optimization in manufacturing. It can identify patterns and trends in production data, leading to improvements in product quality and efficiency. This study presents the application of the BJ method for the identification of a batch milk cooling process. The primary goal of this research is to create a model for the batch milk cooling process, intending to ease the control and enhance the optimization of milk cooling procedures. The data used in this study was collected from a batch milk cooling process over a period of time generated from Simulink. The BJ method was applied to the data to obtain the process transfer function. The model was then used to simulate the batch milk cooling process and tested for different perturbations. The findings indicated that the BJ method effectively represented the batch milk cooling process with high accuracy. The final result obtained from the BJ method is:  $\frac{0.02361}{s + 0.02361}$  which

corresponds to  $\frac{1}{42.3549s + 1}$ .

**Keywords:** Box-Jenkins, Simulation, Dynamic Study, Milk Cooling.

## 1 Introduction

The dairy sector is in charge for the production and the handling of milk and its derived products, encompassing items like cheese, yogurt, butter, and ice cream. [1]–[3]. The dairy industry plays a vital role in the worldwide food sector, and it provides a wide range of dairy products for human consumption and industrial use. Milk production is a primary activity in the dairy industry, and it involves the collection and processing of raw milk from dairy farms. Stringent regulations govern the dairy industry to uphold the wellbeing and excellence of dairy products, with strict standards in place for their production, processing, and marketing [4], [5].

The dairy industry is regulated to guarantee the safety and quality of dairy products, safeguarding consumers from potential harmful contaminants or pathogens. Government agencies and organizations, like the FSANZ (Food Standards Australia New Zealand) in Australia and New Zealand, the EFSA (European Food Safety Authority) in

the EU, the FDA (Food and Drug Administration) in the US, are usually responsible for overseeing the regulation of the dairy industry.

The regulations in the dairy industry typically cover a wide range of areas, including:

1. Milk production: Regulations for dairy farming, including guidelines for the care and treatment of dairy animals, and standards for the collection and storage of raw milk.
2. Milk processing: Regulations for the processing and handling of raw milk to produce dairy products, including standards for pasteurization, homogenization, and the addition of other ingredients.
3. Product labeling: Regulations for the labeling of dairy products, including information about ingredients, nutrition, and allergen warnings.
4. Product testing: Regulations for the testing of dairy products to ensure that they meet established standards for safety, quality, and composition.
5. Food safety: Regulations for the prevention of food-borne illness, including standards for sanitation, packaging, and storage of dairy products.

Milk cooling is an important process in the dairy industry [6], as it affects the quality and safety of the final product. The batch milk cooling process is a dynamic process that is difficult to control and optimize. Therefore, there is a need for a model that can accurately represent the batch milk cooling process.

The BJ method is a well-known system identification method that has been applied in several fields, and it has been shown to be effective in modeling dynamic processes. In their study, Serfidan et al. introduced an automated tool that applies the Box-Jenkins methodology to predict crude oil prices and its primary products for the upcoming two months at the start of each month [7]. Guleryus constructed a Box-Jenkins forecasting model, utilizing statistical data for Turkey aiming to manage and mitigate the transmission of the COVID-19 virus [8]. Shadab et.al examined the application of the Box-Jenkins method to model solar radiation under varying sky conditions, providing insights into predicting and analyzing future trends of monthly insolation through the examination and study of temporal data [9]. In this study, the BJ method was applied to the batch milk cooling process to develop a model that could be used to control and optimize the process. This paper extends the works in [10], which derived the milk cooling transfer function through the heat balance equation, and [11] which identified the system through the ARX (Auto Regressive eXogenous) method. Agustriyanto and Mochni [10] have developed a model for batch milk cooling that will be used in this research to generate data. The BJ identification model has not been previously used to analyze the data and identify this process, and this is the novelty of this paper.

## 2 Batch Milk Cooling Process

The subject of examination is the milk cooling system owned by Cooperative SAE Pujon, illustrated in Figure 1, [10]– [14]. This system includes a rectangular tank with an integrated half-cylindrical tank used to hold the milk. The box-shaped tank is responsible for water-cooling, while the half-cylindrical tank serves as the milk container. The design associated with the tank can be observed in Figure 2.

The transfer function of the process was derived previously [12], [13] and the results obtained are as follows:

$$\frac{T_o(s)}{T_i(s)} = \frac{1}{42.3548s + 1} \quad (1)$$

Equation (1) represents a first-order transfer function in the Laplace domain, characterized by a gain of 1 and a time constant of 42.3548 minutes.



Fig. 1. The Packo milk cooling system, provided by KUD SAE Pujon.

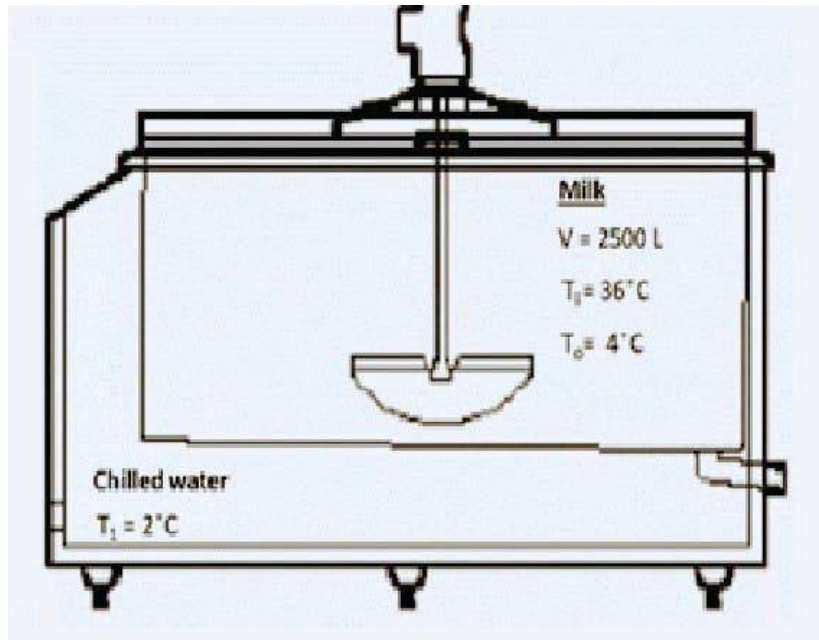

Fig. 2. A perspective from the side of the milk cooling system.

Table 1 displays process specifications for the simulation.

**Table 1.** Process specifications

Variables	Description	Data points	Measurements
V	The tank volume	2,500	L
Cp	Heat capacity of the milk	3.93	kJ/kg.K
ρ	Density of the milk	1,027	kg/m <sup>3</sup>
Q	The heat dissipation from hot fluid (milk) to cold fluid (water)	2,690.74	kJ/min
M	The milk quantity (mass) inside the tank	2,567.5	kg
U	The factor that represents the overall heat transfer rate	274.4613	kJ/min.m <sup>2</sup> . °C
A	The heat transfer area	0.8680	m <sup>2</sup>
T <sub>i</sub>	The inlet milk temperature	36	°C
T <sub>1</sub>	The chilled water temperature	2	°C
T <sub>o</sub>	The milk temperature inside the tank	4	°C

### 3 Box-Jenkins (BJ) System Identification

The method involves four steps [15]:

1. Model Selection: Identifying a suitable mathematical model that can describe the behavior of the system being analyzed.
2. Model Estimation: Determining the parameters of the chosen model by utilizing past data on the system's response.
3. Model Checking: Ensuring the reliability of the estimated model by comparing the actual and estimated values of the system's response.
4. Model Forecasting: Using the estimated model to make predictions of the system's future behavior.

Box-Jenkins model is represented by [16]–[18]:

$$y(t) = \frac{B(q)}{F(q)} u(t - k) + \frac{C(q)}{D(q)} e(t) \tag{2}$$

in which:

- B, F, C, D are polynomials.
- n<sub>b</sub> = the degree of the B + 1 (N<sub>y</sub> by N<sub>u</sub> matrix)
- n<sub>f</sub> = the degree of the F (N<sub>y</sub> by N<sub>u</sub> matrix)
- n<sub>c</sub> = the degree of the C (column vector of N<sub>y</sub> entries)
- n<sub>d</sub> = the degree of the D (column vector of N<sub>y</sub> entries)
- n<sub>k</sub> = the delay in input (in number of samples, N<sub>y</sub> by N<sub>u</sub> matrix)
- N<sub>u</sub> = the count of inputs
- N<sub>y</sub> = the count of outputs

From the input and output data, the Box-Jenkins models to be examined are BJ22221 and BJ11111. As soon as both models are obtained, they can be simulated (either as discrete or continuous models). Converting a discrete model into a continuous one is a straightforward process in MATLAB environment. Continuous transfer function models can be compared immediately with those obtained from mechanistic model, and the simulation results can be visualized through graphs

## 4 Results and Discussion

Assume that the process transfer function is unknown, and we intend to identify it using the Box-Jenkins model. To achieve this, Equation (1) was simulated in Simulink, where disturbances were introduced to the input (the temperature of the cooling water.) as depicted in Figure 3. The corresponding output (the temperature of the milk contained in the tank) is presented in Figure 4. Subsequently, the input-output data was subjected to identification using the Box-Jenkins method.

Using the MATLAB Identification Toolbox, by default the order of the polynomials Box Jenkins method is BJ22221, which means that  $n_b = n_c = n_d = n_f = 2$  and  $n_k = 1$ . We can also identify the data by different order such as BJ11111 ( $n_b = n_c = n_d = n_f = n_k = 1$ ). This will result in a first-order transfer function in the s-domain. The comparison for the two orders is shown in Table 2.

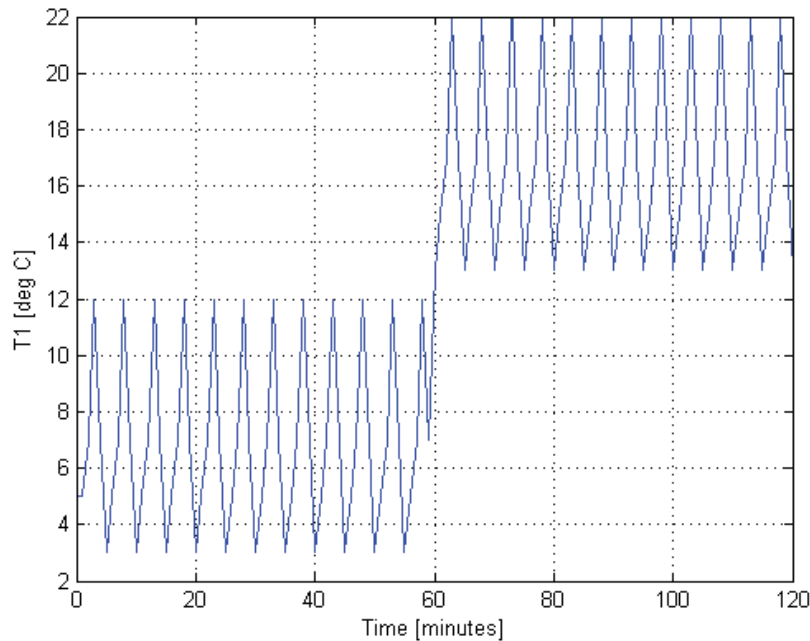

**Fig. 3.** Input profile.

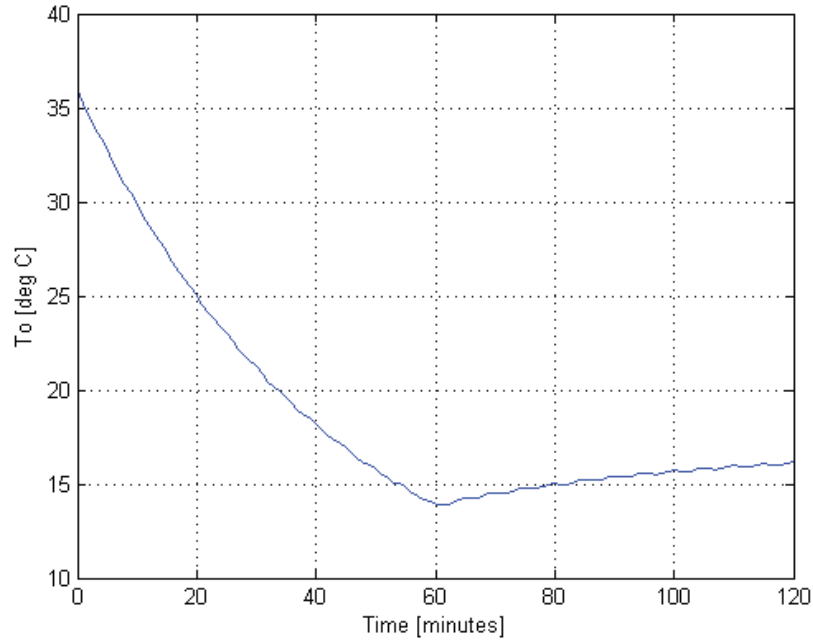

**Fig. 4.** Output profile.

**Table 2.** Box-Jenkins Model

Model	Transfer Function (z) Discrete	Transfer Function (s) Continuous
<b>bj22221</b>	$\frac{0.02333z^{-1} + 0.00746z^{-2}}{1 - 0.6569z^{-1} - 0.3123z^{-2}}$	$\frac{0.02361s^2 + 0.05385s + 0.2637}{s^3 + 2.304s^2 + 11.22s + 0.2637}$
<b>bj11111</b>	$\frac{0.02333z^{-1}}{1 - 0.9767z^{-1}}$	$\frac{0.02361}{s + 0.02361}$

A discrete model (in the z-domain) is essentially the same as a continuous model (in the s-domain) and only differs in the sampling time used to obtain data.

The transfer functions obtained from Table 2 were then retested on certain other forms of perturbations (series of step up as depicted in Figure 5) of cold-water temperature. Figure 6 displays a comparison of the response of the Box-Jenkins model plot with Equation 1 (mechanistic model. It can be seen that the line of series 1 (— obtained from transfer function), series 2 (+ from bj22221), and series 3 (bj11111) overlap. This overlapping indicates that both models (BJ22221 and BJ11111) can represent the process effectively. It should be noted that the final result of bj11111 is also a single order

process, equivalent to  $\frac{1}{42.3549s+1}$  (comparable to equation 1 which is  $\frac{T_o(s)}{T_i(s)} = \frac{1}{42.3548s+1}$ ). The two values are quite similar. Both of them have a gain of 1 and a time constant of around 42.355 minutes.

When compared to identification using ARX [13] (i.e.  $\frac{1}{42.3729s+1}$ ), BJ provides more accurate results.

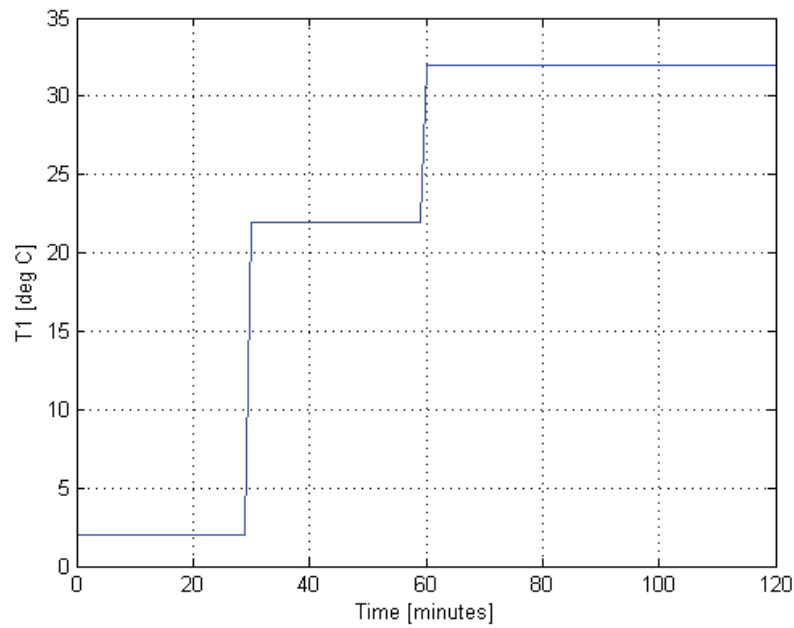

**Fig. 5.** Input testing.

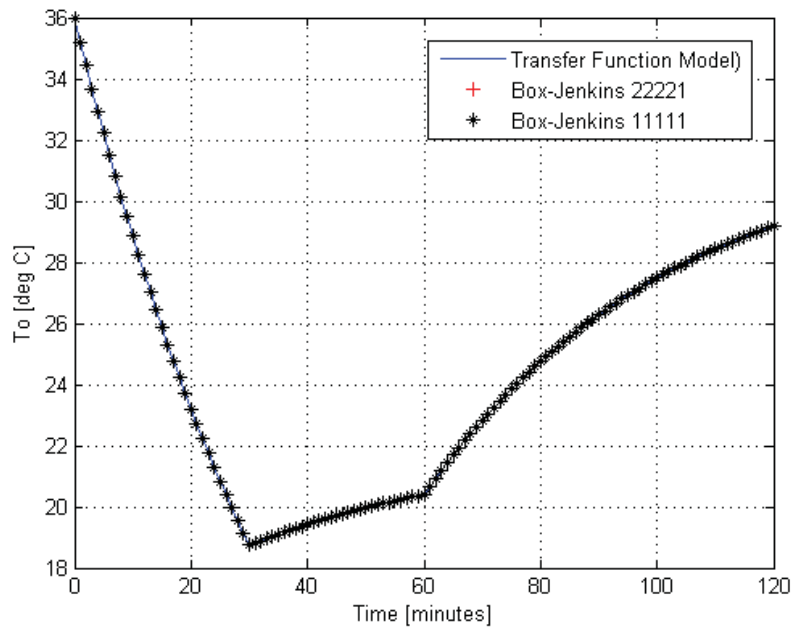

**Fig. 6.** Comparison of Transfer Function Model (—) with Box-Jenkins 22221 (+) and Box-Jenkins 11111 (\*).

## 5 Conclusions

The BJ method was able to accurately model the batch milk cooling process. This is supported by the comparison of the obtained transfer functions with Equation 1 and the results from ARX system identification [13]. This study demonstrates the effectiveness of the BJ method in modeling dynamic processes, and it has potential applications in the dairy industry.

## 6 Acknowledgements

We wish to convey our appreciation to the UBAYA (Universitas Surabaya) for their invaluable support in conducting this research.



## References

1. D. Simón, C. Perez Battistessa, D. Cazzaniga Arduzzo, S. Gass, and A. Cristóbal.: Valorization of sludge from the effluent treatment of the dairy industry as clay substitutes in building bricks. *Constr Build Mater*, vol. 307, p. 124955, 2021, doi: <https://doi.org/10.1016/j.conbuildmat.2021.124955>.
2. M. Custodio, R. Peñaloza, C. Espinoza, W. Espinoza, and J. Mezarina: Treatment of dairy industry wastewater using bacterial biomass isolated from eutrophic lake sediments for the production of agricultural water. *Bioresour Technol Rep*, vol. 17, p. 100891, 2022, doi: <https://doi.org/10.1016/j.biteb.2021.100891>.
3. E. Jachimczyk and R. Myhan: Generation of alternative methods for managing raw materials to support decision-making in the dairy industry. *Food and Bioproducts Processing*, vol. 133, pp. 140–152, 2022, doi: <https://doi.org/10.1016/j.fbp.2022.04.001>.
4. C. I. Pardo Martínez, A. Cotte Poveda, and D. R. Torralba Barreto: Diagnosis and baseline refrigerant use in the Colombian meat, dairy, and fruit and vegetable industries. *International Journal of Refrigeration*, vol. 131, pp. 448–458, 2021, doi: <https://doi.org/10.1016/j.ijrefrig.2021.08.017>.
5. S. Zhong, J. Li, and Y. Qu: Green total factor productivity of dairy cow in China: Key facts from scale and regional sector. *Technol Forecast Soc Change*, vol. 183, p. 121949, 2022, doi: <https://doi.org/10.1016/j.techfore.2022.121949>.
6. D. S. Ayoub, R. Hargiyanto, and A. Coronas: Ammonia-based compression heat pumps for simultaneous heating and cooling applications in milk pasteurization processes: Performance evaluation *Appl Therm Eng*, vol. 217, p. 119168, Nov. 2022, doi: [10.1016/J.APPLTHERMALENG.2022.119168](https://doi.org/10.1016/J.APPLTHERMALENG.2022.119168).
7. A. C. Serfidan, G. Ozkan, and M. Türkay: Automated Box-Jenkins Methodology to Forecast the Prices of Crude Oil and Its Derivatives. In 31st European Symposium on Computer Aided Process Engineering, M. Türkay and R. Gani, Eds., in *Computer Aided Chemical Engineering*, vol. 50. Elsevier, 2021, pp. 631–636. doi: <https://doi.org/10.1016/B978-0-323-88506-5.50100-5>.
8. D. Guleryuz: Forecasting outbreak of COVID-19 in Turkey; Comparison of Box-Jenkins, Brown's exponential smoothing and long short-term memory models. *Process Safety and Environmental Protection*, vol. 149, pp. 927–935, 2021, doi: <https://doi.org/10.1016/j.psep.2021.03.032>.
9. A. Shadab, S. Said, and S. Ahmad: Box-Jenkins multiplicative ARIMA modeling for prediction of solar radiation: a case study. *International Journal of Energy and Water Resources*, vol. 3, no. 4, pp. 305–318, 2019, doi: [10.1007/s42108-019-00037-5](https://doi.org/10.1007/s42108-019-00037-5).
10. R. Agustriyanto and E. S. Mochni: Dynamic Study and PI Control of Milk Cooling Process. *Int J Adv Sci Eng Inf Technol*, vol. 12, no. 5, 2022.
11. R. Agustriyanto: Regulatory performance of two different tuning methods for milk cooling control system. *IOP Conf. Series: Materials Science and Engineering*, vol. 703, 2019, doi: [10.1088/1757-899X/703/1/012004](https://doi.org/10.1088/1757-899X/703/1/012004).
12. R. Agustriyanto, P. Setyoprato, and E. Srihari. Dynamic study of batch milk cooling process at KUD SAE Pujon. *AIP Conf Proc*, vol. 2470, no. 1, p. 030001, Apr. 2022, doi: [10.1063/5.0080176](https://doi.org/10.1063/5.0080176).

13. R. Agustriyanto, E. S. Mochni, and P. Setyoprato: Auto Regressive eXogenous (ARX) System Identification of Batch Milk Cooling Process. *ASEAN Journal of Chemical Engineering*, vol. 22, no. 2, pp. 218–227, 2022, doi: 10.22146/ajche.70546.
14. R. Agustriyanto, A. Febriyanto, and P. S. Widiawati: Perbandingan kinerja penyetelan Hagglund-Astorm dan Tyreus Luyben pada sistem kendali pendinginan susu. *Jurnal Rekayasa Proses*, vol. 12, no. 2, pp. 10–18, 2018.
15. T. Makoni, G. Mazuruse, and B. Nyagadza: International tourist arrivals modelling and forecasting: A case of Zimbabwe. *Sustainable Technology and Entrepreneurship*, vol. 2, no. 1, p. 100027, 2023, doi: <https://doi.org/10.1016/j.stae.2022.100027>.
16. “What Are Polynomial Models - MATLAB & Simulink”, Accessed: Feb. 11, 2023. [Online]. Available: <https://www.mathworks.com/help/ident/ug/what-are-polynomial-models.html>
17. L. Li, H. Zhang, X. Ren, and J. Zhang: A novel recursive learning identification scheme for Box–Jenkins model based on error data. *Appl Math Model*, vol. 90, pp. 200–216, 2021, doi: <https://doi.org/10.1016/j.apm.2020.08.076>.
18. M. Das, M. Catalkaya, O. E. Akay, and E. K. Akpinar: Impacts of use PID control and artificial intelligence methods for solar air heater energy performance. *Journal of Building Engineering*, vol. 65, p. 105809, 2023, doi: <https://doi.org/10.1016/j.job.2022.105809>.

**Open Access** This chapter is licensed under the terms of the Creative Commons Attribution-NonCommercial 4.0 International License (<http://creativecommons.org/licenses/by-nc/4.0/>), which permits any noncommercial use, sharing, adaptation, distribution and reproduction in any medium or format, as long as you give appropriate credit to the original author(s) and the source, provide a link to the Creative Commons license and indicate if changes were made.

The images or other third party material in this chapter are included in the chapter's Creative Commons license, unless indicated otherwise in a credit line to the material. If material is not included in the chapter's Creative Commons license and your intended use is not permitted by statutory regulation or exceeds the permitted use, you will need to obtain permission directly from the copyright holder.





# Program Book

**Adaptive, Resilient & Collaborative Engineering**  
Towards Faster Recovery & Impactful Solutions

4th Bi-Annual  
**International Conference on Informatics, Technology & Engineering**

Supported by:



PT. INOVASI TEKNOLOGI  
KOSMETIKA



PT Rojokoyo Makmur Indonesia

## Publisher

Universitas Surabaya  
Jl. Raya Kalirungkut  
Surabaya, 60293  
Phone: (62-31) 298-1344  
Email: [ppi@ubaya.ac.id](mailto:ppi@ubaya.ac.id)



## Steering Committee

- Chair** : Assoc. Prof. Dr. Jimmy, S.T., M.I.S.
- Honorary** : Prof. Ir. Joniarto Parung, M.M.B.A.T., Ph.D.
- Members** : Prof. Ir. Lieke Riadi, Ph.D.  
Prof. Ir. Markus Hartono, Ph.D., CHFP, IPM, ASEAN Eng.  
Prof. Restu Kartiko Widi, Ph.D.
- Members** : Assoc. Prof. Ir. Eric Wibisono, Ph.D., IPU  
Assoc. Prof. Dr. Ir. Susila Candra  
Asst. Prof. Susilo Wibowo, S.T., M.Eng.  
Asst. Prof. Putu Doddy Sutrisna, Ph.D.  
Assoc. Prof. Dr. Indri Hapsari  
Assoc. Prof. Dr. Joko Siswantoro  
Asst. Prof. Arum Soesanti, S.T., M.T.  
Assoc. Prof. Dr. Dra. Amelia Santoso  
Assoc. Prof. Dr. Emma Savitri  
Assoc. Prof. Lisana, Ph.D.  
Assoc. Prof. Jaya Suteja, Ph.D.  
Assoc. Prof. Ir. Hudiyo Firmanto, Ph.D.  
Assoc. Prof. Djuwari, Ph.D.





## Organizing Committee

<b>Chair</b>	:	Asst. Prof. Agung Prayitno, S.T., M.Eng., Ph.D.
<b>Vice Chair</b>	:	Asst. Prof. Herman Susanto, S.T., M.Sc.
<b>General Secretary</b>	:	Ms. Claudia Fergy Raintung, S.Psi.
<b>Secretariat</b>	:	Dr. Alexander Yohan Asst. Prof. Marcellinus Ferdinand Suciadi, S.T., M.Comp. Dr. Ong Lu Ki Arizia Aulia Aziiza, S.Pd., M.Kom. Olyvia Novawanda, S.T., M.T. Rafina Destiarti Ainul, S.ST., M.T.
<b>Treasurer</b>	:	Assoc. Prof. Ir. Veronica Indrawati, M.T.
<b>Program</b>	:	Assoc. Prof. Dr. Aloisiyus Yuli Widiyanto Ahmad Miftah Fajrin, S.Kom., M.Kom. Mr. Anang Wahyudi, A.Md. Mr. Donny Irnawan, S.Kom.
<b>Website &amp; Design</b>	:	Asst. Prof. Hendra Dinata, S.T., M.Kom. Mikhael Ming Khosasih, S.Kom., M.M., M.Kom.
<b>Sponsorship</b>	:	Assoc. Prof. Ir. Yohanes Gunawan Yusuf, M.MT. Asst. Prof. Yuwono Budi Pratiknyo, S.T., M.T.
<b>Logistic</b>	:	Mr. Muhamad Yulham Effendy, S.T. Mr. Misdhi, S.T. Mr. Imam Agus Faizal, S.T.





## Technical Program & Scientific Committee

Prof. Benny Tjahjono, Ph.D. (Coventry University, Coventry, England)  
Prof. Dr. Ir. Wahyudi Sutopo, IPM (Universitas Sebelas Maret, Solo, Indonesia)  
Prof. Dr. Pavel Albores (MIET, FHEA) (Aston University, Birmingham, England)  
Prof. Bertha Maya Sopha, Ph.D. (Universitas Gadjah Mada (UGM), Yogyakarta, Indonesia)  
Prof. Dr-Ing. Amalia Suzianti (Universitas Indonesia (UI), Jakarta, Indonesia)  
Assoc. Prof. Dr. Andi Cakravastia Arisaputra Raja (Institut Teknologi Bandung (ITB), Bandung, Indonesia)  
Assoc. Prof. Dr. Connie Susilawati (Queensland University of Technology, Australia)  
Assoc. Prof. Tan Kay Chuan, Ph.D. (National University of Singapore (NUS), Singapore)  
Assoc. Prof. Dr. Naniek Utami Handayani (Universitas Diponegoro, Semarang, Indonesia)  
Prof. Dr. Ing. Ir. I Made Londen Batan (Institut Teknologi Sepuluh Nopember (ITS), Surabaya, Indonesia)  
Prof. Dr. Ir. Joko Lianto Buliali (Institut Teknologi Sepuluh Nopember (ITS), Surabaya, Indonesia)  
Prof. Dr. Ir. Judy Retti B. Witono (Universitas Katolik Parahyangan, Bandung, Indonesia)  
Prof. Ir. Arif Djunaidy, Ph.D. (Institut Teknologi Sepuluh Nopember (ITS), Surabaya, Indonesia)  
Prof. Ir. Djoko Budiyanto, Ph.D. (Universitas Atma Jaya, Yogyakarta, Indonesia)  
Prof. Ir. Joniarto Parung, Ph.D. (Universitas Surabaya, Surabaya, Indonesia)  
Prof. Ir. Lieke Riadi, Ph.D. (Universitas Surabaya, Surabaya, Indonesia)  
Prof. Ir. Markus Hartono, Ph.D., CHFP, IPM, ASEAN Eng. (Universitas Surabaya, Surabaya, Indonesia)  
Prof. Restu Kartiko Widi, Ph.D. (Universitas Surabaya, Surabaya, Indonesia)  
Assoc. Prof. Dina Natalia Prayogo, S.T., M.Sc. (Universitas Surabaya, Surabaya, Indonesia)  
Assoc. Prof. Dr. A. F. M. Saifuddin Saif (American International University, Bangladesh)  
Assoc. Prof. Dr. Benjawan Srisura (Assumption University of Thailand, Bangkok, Thailand)  
Assoc. Prof. Dr. Diana Purwitasari (Institut Teknologi Sepuluh Nopember (ITS), Surabaya)  
Assoc. Prof. Dr. Dra. Amelia Santoso (Universitas Surabaya, Surabaya, Indonesia)  
Assoc. Prof. Dr. Dra. Ir. Evy Herowati (Universitas Surabaya, Surabaya, Indonesia)  
Assoc. Prof. Dr. Emma Savitri (Universitas Surabaya, Surabaya, Indonesia)  
Assoc. Prof. Dr. Ir. Anas Ma'ruf (Institut Teknologi Bandung (ITB), Bandung, Indonesia)  
Assoc. Prof. Dr. Ir. Puguh Setyopratomo (Universitas Surabaya, Surabaya, Indonesia)  
Assoc. Prof. Dr. Ir. Susila Candra (Universitas Surabaya, Surabaya, Indonesia)  
Assoc. Prof. Dr. Joko Siswanto (Universitas Surabaya, Surabaya, Indonesia)  
Assoc. Prof. Dr. Ludovic F. Dumeé (Khalifa University, Uni Arab Emirates (UAE))  
Assoc. Prof. Dr. Mohd Sanusi Azmi (Universiti Teknikal Malaysia Melaka, Melaka)  
Assoc. Prof. Dr. Ridi Ferdiana (Universitas Gadjah Mada (UGM), Yogyakarta, Indonesia)





Assoc. Prof. Dr. Rosita Meitha Surjani (Universitas Surabaya, Surabaya, Indonesia)  
Assoc. Prof. Elieser Tarigan, Ph.D. (Universitas Surabaya, Surabaya, Indonesia)  
Assoc. Prof. Ir. Eric Wibisono, Ph.D., IPU (Universitas Surabaya, Surabaya, Indonesia)  
Assoc. Prof. Satvasheel Powar, Ph.D. (Indian Institute of Technology Mandi, India)  
Assoc. Prof. Teguh Bharata Adji, Ph.D. (Universitas Gadjah Mada (UGM), Yogyakarta, Indonesia)  
Assoc. Prof. The, Jaya Suteja, Ph.D. (Universitas Surabaya, Surabaya, Indonesia)  
Assoc. Prof. Timotius Pasang, Ph.D. (Oregon Institute of Technology, USA)  
Assoc. Prof. Itthisek Nilkhamhang, Ph.D. (Sirindhorn International Institute of Technology, Pathum Thani, Thailand)  
Assoc. Prof. Nemuel Daniel Pah, Ph.D. (Universitas Surabaya, Surabaya, Indonesia)  
Asst. Prof. Dr. Jimmy (Universitas Surabaya, Surabaya, Indonesia)  
Assoc. Prof. Dr.rer.nat. Lanny Sapei (Universitas Surabaya, Indonesia)  
Asst. Prof. Dr. Hazrul Iswadi (Universitas Surabaya, Surabaya, Indonesia)  
Asst. Prof. Dr. Indri Hapsari (Universitas Surabaya, Surabaya, Indonesia)  
Assoc. Prof. Dr. Awang Hendrianto Pratomo (UPN "Veteran" Yogyakarta, Indonesia)  
Asst. Prof. Dr. Hendi Wicaksono Agung Darminto. (Universitas Surabaya, Surabaya, Indonesia)  
Asst. Prof. Djuwari, Ph.D. (Universitas Surabaya, Surabaya, Indonesia)  
Asst. Prof. Dr. Delta Ardy Prima (Universitas Surabaya, Surabaya, Indonesia)  
Asst. Prof. Dr. Drs. Muhammad Rosiawan, M.T. (Universitas Surabaya, Surabaya, Indonesia)  
Asst. Prof. Dr. Yenny Sari (Universitas Surabaya, Surabaya, Indonesia)  
Asst. Prof. Liliana, S.T., M.MSI. (Universitas Surabaya, Surabaya, Indonesia)  
Asst. Prof. Dr. Fredy Purnomo (Universitas Bina Nusantara, Jakarta, Indonesia)  
Asst. Prof. Dr. Khoiruddin (Institut Teknologi Bandung (ITB), Bandung, Indonesia)  
Asst. Prof. Firman Kurniawansyah, Ph.D. (Institut Teknologi Sepuluh Nopember (ITS), Surabaya)  
Asst. Prof. Ratna Surya Alwi, Ph.D. (Universitas Fajar, Makassar, Indonesia)  
Asst. Prof. Monica Widiasri, S.Kom., M.Kom. (Universitas Surabaya, Surabaya, Indonesia)  
Asst. Prof. Drs. Heru Arwoko, M.T. (Universitas Surabaya, Surabaya, Indonesia)  
Asst. Prof. Mohammad Farid Naufal, S.Kom., M.Kom. (Universitas Surabaya, Surabaya, Indonesia)  
Asst. Prof. Yunus Fransiscus, S.T., M.Sc. (Universitas Surabaya, Surabaya, Indonesia)  
Dr. Mohammod Abdul Motin. (Rajshahi University of Engineering & Technology, Rajshahi, Bangladesh)  
Dr. Quoc Cuong Ngo. (RMIT University, Melbourne, Australia)  
Dr. Pyae Pyae Phyo. (Eindhoven University of Technology (TU/e), The Netherlands)  
Dr. Mohamad Rezi bin Abdul Hamid (University Putra Malaysia, Seri Kembangan, Malaysia)  
Maya Hilda Lestari Louk, S.T., M.Sc. (Universitas Surabaya, Surabaya, Indonesia)  
Vincentius Riandaru Prasetyo, S.Kom., M.Cs. (Universitas Surabaya, Surabaya, Indonesia)  
Yuana Elly Agustin, S.T., M.Sc. (Universitas Surabaya, Surabaya, Indonesia)  
Argo Hadi Kusumo, S.T., M.B.A. (Universitas Surabaya, Surabaya, Indonesia)







I Made Ronyastra, S.T., M.T. (Universitas Surabaya, Surabaya, Indonesia)  
Asst. Prof. Andre, M.Sc. (Universitas Surabaya, Surabaya, Indonesia)  
Asst. Prof. Dhiani Tresna Absari, M.Kom. (Universitas Surabaya, Surabaya, Indonesia)  
Asst. Prof. Esti Dwi Rinawiyanti, Ph.D. (Universitas Surabaya, Surabaya, Indonesia)  
Asst. Prof. Gunawan, Ph.D. (Universitas Surabaya, Surabaya, Indonesia)  
Asst. Prof. Jerry Agus Arlianto, M.T. (Universitas Surabaya, Surabaya, Indonesia)  
Dr. Stefanus Soegiharto (Universitas Surabaya, Surabaya, Indonesia)  
Susilo Wibowo, M.Eng. (Universitas Surabaya, Surabaya, Indonesia)  
Henry Hermawan, M.Sc. (Universitas Surabaya, Surabaya, Indonesia)







## Table of Contents

Message from the Rector of University of Surabaya .....	I
Message from Dean of the Faculty of Engineering, University of Surabaya.....	III
Message from INCITE 2023 Steering Committee .....	V
Message from INCITE 2023 Organizing Committee .....	VI
Steering Committee .....	VIII
Organizing Committee .....	IX
Technical Program & Scientific Committee.....	X
INCITE 2023 General Program Schedule .....	1
General Schedule, Day 1.....	1
General Schedule, Day 2.....	2
INCITE 2023 Technical Session Schedule .....	3
Keynote Speakers.....	12
Prof. Dr. Rosemary Seva.....	12
Prof. Ir. Markus Hartono, Ph.D., CHFP, IPM, ASEAN Eng.....	13
Asst. Prof. Dr. Paitoon Portrakoon .....	15
Prof. Dr. Restu Kartiko Widi.....	17
Prof. Ir. Selo, Ph.D., IPU.....	19
MANUFACTURING AND ENGINEERING PROCESSES .....	20
Warehouse Safety in Order Picking .....	20
Designing Smart Contracts on Insurance Claims to Support the Supply Chain Performance .....	20
Measuring E-Service Quality & Webqual 4.0 in ICMS Through Kano Method and Importance-Performance Analysis for Development Strategies .....	21
Lean Manufacturing to Reduce Production Time for Pressure Vessel Production	22
The Application of the Box-Jenkins (BJ) Method for Process Identification of the Batch Milk Cooling System .....	22
Performance and Kinetic Study of Xylan Hydrolysis by Free and Immobilized Trichoderma Xylanase .....	23
Influence of Inulin and Isomalto-oligosaccharides as Thickener on the Stability of Vitamin C Containing W1/O/W2 Double Emulsion.....	24
Effect of The Amount of KIO <sub>3</sub> , Water, and Stirring Time on Salt Quality in The Iodization Process.....	25
Carboxylated Multi-walled Carbon Nanotubes/Calcium Alginate Composite for Methylene Blue Removal.....	25
Delignification and Characterization of Fiber from Durian Peel Waste.....	26
Lean and Green Value Stream Mapping: Case Study of an East Java Furniture Factory .....	27
The Adoption of the Response Surface Methodology within the DMAIC Process to Achieve Optimal Solutions in Reducing Product Defect.....	27





Behavior of Vehicle Platoon with Limited Output Information Based on Constant Time Heading.....	28
The Interaction Effect of CaCo3 Composition, Injection Temperature, and Injection Pressure on the Tensile Strength and Hardness of Recycled HDPE.....	29
Comparing the Effects of Efficiency and Distortion in Audio Power Amplifiers with and without Tracking Power Supply Circuit Design.....	29
Risk Analysis to Mitigate Dominant Risk of Electrical Infrastructure Construction .....	30
Reducing Procurement Waiting Time Through Lean Six Sigma.....	31
A Model for Evaluating the Impact of Priority Rules on Flow Time and Wait Time In A Job Shop Scheduling System: A Single Machine Case .....	31
Modeling and Optimization of Location Selection of Fuel Terminal Considering Vessels and Pipeline Operations.....	32
Lean Six Sigma and TRIZ to Reduce Non-Value-Added Activities of the Transformer Production Process .....	33
Driving Growth in Village Industries: Exploring Effective Financing Facilities for Micro and Small Enterprises.....	33
Remarshaling in A Bin-to-Person-based Smart Automated Warehouse.....	34
Comparison of Classification Machine Learning Models for Production Flow Analysis in a Semiconductor Fab .....	35
ENGINEERING DESIGN AND INNOVATION.....	36
Circular Economy at LNG Bontang Company: Transforming Aluminium Jacketing Waste Into Sacrificial Anode Products.....	36
Restructuring Job Design Using Job Analysis to Balance Workload and Enhance Productivity.....	36
Design of Mid Drive Electric Cargo Bike for Urban Area .....	37
The House of Risk with Multi-Actor Approach Aligned with ISO 31000:2018 for Effective Risk Management in Business with Risky Environment .....	38
Centralized AGV Control Systems based on OutsealESP32 PLC and ESP-NOW Protocol .....	39
Improving Loading and Unloading Performance at Patimban Port Car Terminal with a Lean Strategy .....	39
The Influence Of Noise Factors On Concentration Based On Eeg Signal.....	40
Indonesia e-Bike Consumer Preference Through Market Potential Research: A Choice-based Conjoint Analysis.....	41
Electric Vehicle Charging Allocation Considering Electricity Price Fluctuation Company.....	41
Overview of Ergonomics and Safety Aspects of Human-Cobot Interaction in the Manufacturing Industry.....	42
POWER SYSTEMS AND ENERGY MANAGEMENT .....	43
Performance Evaluation of Roof Tile Solar PV under Tropical Climate of Surabaya, Indonesia .....	43
THE ROLE OF IT FOR INNOVATION ENHANCEMENT.....	43





Implementation of K-Means and K-Nearest Neighbor Methods for Laptop Recommendation Websites.....	43
Implementation of Recency, Frequency, and Monetary Patterns in Adaptive Blockchain-Based Transactions.....	44
Electronic Election for Small Medium Non-Profit Organizations in Indonesian Cities .....	45
Online Claim and Guarantee Mechanism for Electronics Peripheral in Urban Country .....	45
Perceived Usability Evaluation of IRiS: an Integrated Recommendation Collection System .....	46
Incorporating Interactive Elements into Children's Storybook to Improve Children's Motivation to Learn Bible: Case Study on the Parable of the Sower .....	47
Development of Artificial Immune System in Multi-Objective Vehicle Routing Problem with Time Windows .....	47
Has Website Design using Website Builder Fulfilled Usability Aspects? A Study Case of Three Website Builders .....	48
Design of Employee Bus Routes for Madiun City Government Based on Home Locations and Presence Location History .....	49
Arabic Letter Classification Using Convolutional Neural Networks for Learning to Write Quran.....	50
Alveolar Bone Quality Classification from Dental Cone Beam Computed Tomography Images using YOLOv4-tiny .....	50
Exploring the Impact of Mobile-Based 3D Simulation on Student's Achievement and Satisfaction in Physics Education.....	51
An Encrypted QR Code Using Layered Numeral Calculation for Low Powered Devices.....	52
Spices Identification in Essential Oil Producers using Comparasion of KNN and Naïve Bayes Classifier .....	53
Long Short-Term Memory Method Based on Normalization Data for Forecasting Analysis of Madura Ginger Selling Price .....	53
Analyzing the Probability Density Distribution of Sustained Phoneme Voice Features in the PC-GITA Dataset for Parkinson's Disease Identification .....	54
Drowsiness Eye Detection using Convolutional Neural Network.....	55

