



Design of Mid Drive Electric Cargo Bike for Urban Area

Sunardi Tjandra¹, Susila Candra¹, Albertus Agung Jody Saputra¹ and Yehezkiel D. Faraisc Putra¹

¹ Department of Mechanical and Manufacturing, University of Surabaya, Raya Kalirungkut, Surabaya, Indonesia
s_tjandra@staff.ubaya.ac.id

Abstract. Some couriers use bicycles for work. However, it is not efficient because relies on their stamina, which can affect the delivery duration and capacity. E-bike can be a solution to this problem. However, its price is unaffordable for most couriers. It is necessary to modify the couriers' bicycles into e-bike. They simply need to purchase the appropriate electric motor device and battery, and then assemble them onto their bicycles following specific procedures. Generally, electric motor device is used to drive the rear wheel. Courier's cargo basket is located at the back of the bicycle, causing a shift in bicycle's center of mass towards the rear. Mid-drive electric motor devices are expensive and require extensive modifications to bicycle frame. Therefore, it is necessary to design and modify the rear-wheel electric motor device into a mid-drive system, making the bicycle more stable and safer for delivering goods at an affordable price. Design process involves studying literature and data, concept generation, analysis of electric motor and battery, control system design, motor bracket design, and transmission design, and prototyping. Total load capacity of mid-drive train e-cargo bike is 143 kgf, average speed 25 km/h on flat roads. This e-cargo bike uses MY1016Z2 electric motor with specification 250 W, 24 V, gear ratio 1:9.78, and throttle control system. The battery used is LiFePO4 24V/80Ah. The electric motor requires 200 W, with 8.33-ampere current. The maximum range of the electric bicycle is 240 km, with a maximum usage duration of 9.6 hours.

Keywords: Electric Cargo Bike, Mid Drive, Electric Motor

1 Introduction

Since the Covid-19 pandemic, there has been a substantial increase in online shopping facilitated by e-commerce platforms and social media. As a result, there has been a significant rise in the number of people transitioning to the profession of delivery couriers. Traditionally, couriers utilize motorcycles for the pickup and delivery of goods. However, due to economic considerations, there is also a notable presence of couriers who opt for bicycles as their mode of transportation.

Crucial factors for the successful implementation of electric cargo biking seem to include electric range, purchase price, and the availability of public information [1].

The findings highlighting the advantages of implementing e-cargo bikes indicate that these bikes have the potential to substitute approximately 10% of traditional vehicles within areas where the maximum linear distance is about 2 km. Furthermore, incorporating cargo bikes into urban logistics can result in a reduction of up to 73% in Well-to-Wheel (WTW) CO₂ emissions, which is equivalent to avoiding 746 kg of CO₂ emissions [2]. The increasing use of e-bikes for daily tasks, such as transporting children, coupled with factors like safety enhancements, accessory availability, and technological advancements, encourages the ongoing functional improvement and adoption of e-cargo bikes [3].

Electric assisted bicycles (e-Bikes) represent an emerging sustainable mode of transportation for the smart cities of the future. Several design issues have an impact on policies in several developed countries. The use of e-bikes continues to grow, and a wider, more diverse and sustainable mode of transportation can be adopted [4]. The study introduces the concept of utilizing cargo bikes in urban logistics, with electric-assisted bicycles (e-Bikes) emerging as a new concept [5]. From an economic perspective, utilizing e-bikes and e-scooters for smart logistics can lead to cost savings. Electric vehicles generally have lower operational and maintenance costs compared to their gasoline or diesel counterparts. The use of e-bikes and e-scooters can also help reduce fuel expenses, as they rely on electricity as a power source. E-bikes and E-scooters for smart logistics: environmental and economic sustainability in pro-E-bike Italian project [6]

Based on the information above, cargo bikes in several developed countries have been implemented which leads to the use of e-cargo bikes. The constraints and concepts have been implemented with the specifics of each country. While the implementation in Indonesia is not as massive as in these developed countries. Traditional bicycle modifications are changed to e-cargo bikes to be a good choice to implement.

The use of bicycles is cost-effective as they are easy to maintain and do not require fuel, making them environmentally friendly. However, when used for delivery purposes, pedal-powered bicycles are less efficient as they heavily rely on the courier's stamina and health. Couriers with poor stamina easily tire, affecting the duration and capacity of deliveries.

One solution to address these issues is the use of electric bicycles. However, the electric bicycles available in the market are often expensive and not affordable for couriers. Therefore, an alternative solution is needed based on the needs and conditions of the community, particularly couriers. This solution involves designing and modifying their pedal-powered bicycles into electric bicycles. Couriers can purchase suitable electric motor devices and batteries, and then assemble them onto their bicycles following specific procedures.

Electric motor devices and batteries for electric bicycles are already available in the market. However, they are not necessarily suitable when applied to bicycles used for delivery purposes. The electric motor devices commonly available in the market are designed for rear-wheel drive, causing the bicycle's center of mass to shift backward. Additionally, the courier's cargo basket is located at the rear of the bicycle. This arrangement significantly affects the safety and comfort factors. On the other hand,

mid-drive electric motor devices available in the market are expensive and require substantial modifications to the bicycle frame.

Therefore, there is a need to design a mid-drive electric motor device using existing rear-wheel drive devices, to ensure that the bicycle is stable and safe for delivering goods while remaining affordable.

2 Design Method

The design process begins with identifying the requirements, conducting literature studies, and collecting supporting data, which are summarized in the form of design specifications. These design specifications serve as the basis for concept development. The design concept focuses on the type and placement of the motor, selection and placement of the battery, as well as the design of the mechanism and control system. The next stage involves component design and engineering analysis. This stage includes analyzing the requirements for the electric motor and battery, designing the control system, motor bracket design, and transmission design. The prototype is made based on that engineering design and analysis results.

3 Literature Review

In general, an electric bicycle (e-bike) consists of a brushless DC Motor, an accelerator, rechargeable battery, chain drive, Frame and other common bicycle components [7]. The performance of e-bike is affected by factors such as motor power, battery capacity, operational weight, road types, control, and power management [8].

There are two types of electric motors used in electric bicycles, namely mid-drive and hub motors. A mid drive motor is mounted in the middle of the frame. It powers the cranks and sends force through the drive train. This has the advantage of being able to tackle hills with ease when combined with a gearing system which most mid drive e-bikes come with. A mid drive motor is lighter than most hub motor e-bikes. A hub drive motor, which is located within the rear or front wheel of the bike and powers the motion of the wheel itself. A throttle and/or a pedal assist generally drive it. It moves the wheel forward through a motor driven in the wheel itself and generally use a higher rated power motor. It has climbing difficulty due to no gearing.

Currently, there are two types of control systems (accelerators) for electric bicycles: pedal assist and throttle. The pedal assist system uses a cadence sensor to detect the rotation of the crank arm. The crank arm needs to rotate 180 degrees or 360 degrees to activate the electric motor. On the other hand, the throttle control system operates similarly to the throttle on a motorcycle, where you rotate the handlebar grip to control the speed of the bicycle (twist the handgrip). The more twist on the grip, the more current delivered to the motor resulting in higher RPMs from the motor.

The bike transmission mechanism uses a sprocket and chain mechanism. This mechanism consists of two parts, namely the crankset/chain set and the cassette. Crankset is the component of a bicycle drivetrain that converts the reciprocating mo-

tion of the rider's legs into rotational motion used to drive the chain, which in turn drives the rear wheel. Cassette is a cluster of sprockets that are a part of the drivetrain.

Differently from a common approach, in which the electric motor is located on one of the three hubs of the bicycle, the idea of the pedelec (pedal electric cycle) prototype consists of an electrical motor in the central position that, by means of a bevel gear, transmits the torque on the central hub. The other innovative solution is represented by the motion transmission from the motor to the pedal shaft [8]

4 Design of E-cargo Bike and Power Theory

4.1 Design Concept

Table 1 below is the design specifications for the e-cargo bike.

Table 1. Design Specifications for mid drive e-cargo bike.

Factor	Information
Bike type	Mountain Bike Hard Trail
Frame size	L
Maximum mass of carried object	20 kg at the rear part of bike
Maximum mass of cyclist	100 kg
Maximum velocity	25 km/h
Control System	throttle

Mid-drive electric device is used to rotate the front sprocket of a bicycle (on the crankset). The crankset is located in the middle of the bicycle, between the front and rear wheels. Therefore, the electric motor is placed in the area around the crankset. The suitable area on the bicycle frame for mounting the electric motor is near the seat tube and down tube, either above or below the down tube. In this design, the electric motor is positioned between the seat tube and down tube.

Installing the electric motor onto the bicycle frame requires an additional component called an electric motor bracket. The bracket serves to hold the motor in place, preventing it from moving and maintaining stability when the electric bicycle is in use. The electric motor used is the type that drives the rear wheel sprocket, so a suitable bracket needs to be designed, if the electric motor is used for drives the front sprocket of the bicycle. The following factors are taken into consideration in the selection of the design concept: 1) Center of gravity analysis in various conditions: parking, acceleration, turning, going uphill or downhill; 2) Manufacturing and assembly process: the use standard components; 3) Maintenance process: battery charging, spare part replacement, cleaning, lubrication, and others; 4) Manufacturing cost.

Figure 1 is the selected design concept of mid drive e-cargo bike (see Fig. 1).

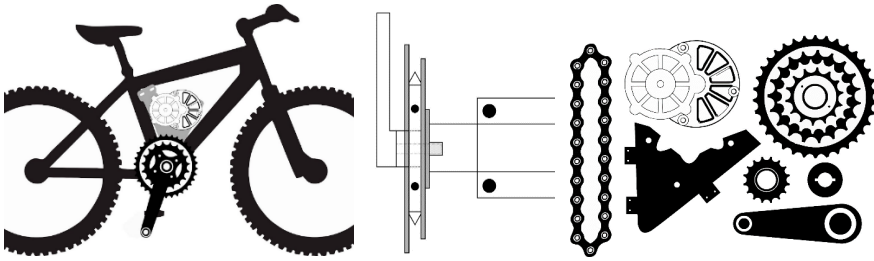

Fig. 1. Selected design concept of mid drive e-cargo bike

As shown in Figure 1, the electric motor bracket is installed between the seat tube and the down tube. The electric motor is assembled onto the bracket using bolts, washers, and nuts. A sprocket is mounted on the motor shaft and connected to the crankset sprocket using a chain. The smaller-sized crankset sprocket is connected to one of the sprocket on the cassette using a chain. When the throttle is engaged, the electric motor sprocket will rotate the crankset sprocket. The smaller crankset sprocket will then rotate the cassette sprocket, causing the rear wheel of the bicycle to rotate.

The crankset in this concept is slightly modified by adding a free wheel to the crankset sprocket connected to the electric motor sprocket. The freewheel serves to separate the rotation of the crankset sprocket connected to the motor sprocket from the smaller crankset sprocket (connected to the cassette). As the result, when the electric motor is active, the pedal arms do not rotate, preventing the cyclist's legs from moving (similar to using a motorbike). Vice versa, when the cyclist pedals the bicycle, the electric motor shaft does not rotate.

4.2 Electric Motor Power Analysis

Table 2 is the basic specifications for electric motor requirement analysis. Table 3 is data for electric motor requirement analysis.

Table 2. Basic specifications for electric motor analysis.

Factor	Information
Max. speed of e-cargo bike	25 km/h, in accordance with the regulations set by the Ministry of Transportation (Permenhub) No. 45/2020 regarding specific vehicles using electric motor propulsion
Maximum cyclist mass	100 kg, according to the maximum load capacity of a mountain bike.
Maximum cargo mass	20 kg
Maximum cargo dimension	30 cm x 30 cm x 30 cm
Electric motor mass	3 kg

Table 3. Data for electric motor requirement analysis.

Factor	Information
Theoretical max. speed (v)	40 km/h (11.11 m/s). This speed is reached within 10 seconds from a stationary position.
Wheel air pressure	35 psi, in accordance with the maximum air pressure for mountain bike wheel (25 - 35 psi).
Wheel diameter	29 inches = 0.736 meters
Road Gradient (tan θ)	5% = 0.05

4.3 Torque and Power of Motor

The initial stage of the electric motor requirement analysis involves calculating the propulsive force of the electric bicycle. The propulsive force is calculated based on two conditions. The first condition is when the electric bicycle reaches its maximum speed within a specific time from a stationary position. The second condition is when the electric bicycle is traveling at its maximum speed. The propulsive force of the electric bicycle under the first condition, F_t , consists of three forces: the acceleration force F_m , the rolling resistance force F_r , and the slope force F_s . The equation for calculating the propulsive force under the first condition is as follows:

$$F_t = F_m + F_r + F_s \quad (1)$$

$$= m \cdot a + \mu_r \cdot m \cdot g + m \cdot g \cdot \sin \theta \quad (2)$$

$$= m \cdot (a + \mu_r \cdot g + g \cdot \sin (\tan^{-1} \theta)) \quad (3)$$

From equation 3: m represents the total mass of the electric bicycle, which is 143 kg = 1402.83 N. μ_r represents the rolling resistance coefficient between the tires and the road, θ represents the road gradient.

The total mass of the electric bicycle consists of the weight of cyclist + cargo + motor and battery + bicycle. The first step in the analysis of the electric motor requirement for the first condition is to calculate the maximum acceleration a . The maximum acceleration is calculated based on the maximum speed and the time required to reach that maximum speed (from a stationary position). The maximum acceleration is calculated using the equation:

$$V_t = V_o + a \cdot t \quad (4)$$

where: V_t is the maximum velocity, V_o is the initial velocity, t is the time taken by the e-bike to reach the maximum velocity, and a is the maximum acceleration.

The next step is to determine the coefficient of rolling resistance between the wheel and the road. The coefficient of rolling resistance is influenced by tire pressure, suspension type, and bicycle wheel diameter [9]. The road gradient for the highway is determined to be 5% [10].

After calculating the propulsive force of the electric bicycle, the next step is to calculate the torque at the wheel, as well as the torque and power of the motor. The equation used to calculate the torque and motor power are as follows:

$$M_t = F_1 \cdot r \quad (5)$$

where: M_t is the torque at the wheel, F_1 is the maximum propulsive force of the electric bicycle under the first condition, and r is the radius of the bicycle wheel. The torque at the wheel is transmitted to the motor torque M_r , through a gear transmission and sprocket-chain with a specific ratio. The power of the electric motor is calculated using the following equation, where v is the maximum speed of the electric bicycle:

$$P = M_r \cdot \omega \quad (6)$$

$$P = M_r \cdot (v/r) \quad (7)$$

Propulsive force of the electric bicycle under the second condition, F_2 , consists of three forces: rolling force F_r , slope force F_s , and drag force F_d . The drag force is influenced by the air density ρ_a (1.2 kg/m^3), drag coefficient C_A , and frontal area A_f . The equation to calculate the propulsive force under the second condition is as follows:

$$F_2 = F_r + F_s + F_d \quad (8)$$

$$= \mu_r \cdot m \cdot g + m \cdot g \cdot \sin(\tan^{-1}\theta) + (0.5 \cdot \rho_a \cdot v^2 \cdot C_A \cdot A_f) \quad (9)$$

5 Result and Discussion

5.1 Electric Motor Power

From the calculation using equation 4, the maximum acceleration of the electric bicycle is 1.11 m/s^2 . The rolling resistance coefficient μ_r is determined to be 0.011. Using equation 3, the propulsive force of the electric bicycle under the first condition, F_1 , can be calculated as follows:

$$\begin{aligned} F_1 &= 143 \times (1.11 + (0.011 \times 9.81) + (9.81 \times \sin 2.86^\circ)) \\ &= 244.16 \text{ N} \end{aligned}$$

Using equation 5, the torque at the wheel M_t , is calculated to be 89.85 Nm. The torque at the wheel is transmitted to the motor through a gear transmission and sprocket-chain with a ratio of 20, resulting in a motor torque M_r of 4.5 Nm. Using equation 7, power of the electric motor is calculated to be 135.85 W. Assuming a motor efficiency of 80%, the required electric motor power under the first condition is approximately 169.82 W, which is rounded to 200 W.

To calculate the propulsive force of the electric bicycle under the second condition, the drag coefficient C_A and frontal area A_f are determined to be 0.422 and 0.472 respectively [11], [12]. Therefore, the total propulsive force under the second condition is 100.24 N. The torque at the wheel is calculated to be 36.89 Nm. With a transmission ratio of 20, the motor torque M_r , is 1.85 Nm. Using equation 7, the power of the electric motor to be 55.85 W. Considering an 80% motor efficiency, the required motor power under the second condition is approximately 69.82 W, which is rounded to 70 W.

Based on the analysis of the electric motor requirements, the e-cargo bike design will utilize an electric motor with the following specifications: 250 W/24 V, 3300 rpm, and a gear ratio of 1:9.78. The selected electric motor is of type MY1016Z2, commonly used for electric bicycles with rear-wheel drive, requiring the electric motor mounting bracket to be placed only at the rear part of the bike frame. As mentioned earlier, in this design, the electric motor is positioned in the middle of the bike and drives the crankset. Therefore, a motor bracket needs to be designed according to the specifications mentioned above.

5.2 Battery Capacity

The battery requirements for the electric bicycle are calculated based on the specifications of the electric motor, which is 250 W/24 V. The analysis of battery requirements begins by calculating the theoretical current strength required by the electric motor. The next step is to calculate the battery's watt-hour capacity, considering its efficiency, and then converting it into ampere-hours.

To run a 250-watt motor for 1 hour, a battery with a specification of 24V 15AH is required. With an average speed of 25 km/h for the electric bicycle, the theoretical distance that can be covered in one hour of battery usage is 25 km. The e-cargo bike design utilizes a LiFePO₄ battery with a specification of 24V/80Ah. With an average speed of 25 km/h, the maximum theoretical distance that can be covered is 130 km, with a maximum usage duration of 3.2 hours.

From the analysis results, the required power of the electric motor is 200 W. With a supply voltage of 24 volts, the current required is approximately 8.33 Ampere. The maximum range of the electric bicycle is 240 km, with a maximum usage duration of 9.6 hours.

5.3 Design of Electric Motor Bracket

Electric motor is positioned between the seat tube and the down tube. Factors that affected the design of electric motor bracket include the dimensions, shape, and mass of the electric motor; dimensions of the seat tube and down tube; angle between the seat tube and down tube, and motor torque. The dimensions of the electric motor are as follows: width of 115 mm, diameter of 101 mm, and height of 130 mm. The mass of the electric motor is 3 kg.

Average diameter of the seat tube is 32 mm. Diameter of the down tube varies from 32 mm to 45 mm. Angle α represents the angle between the seat tube and the down tube (see Fig. 2). Its value varies between 51 degrees to 60 degrees.

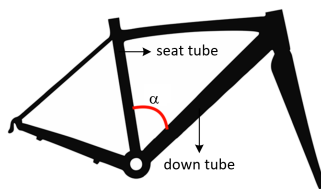

Fig. 2. Angle between seat tube and down tube on bicycle frame

Figure 3 is digital 3d model of electric motor bracket (see Fig. 3). Figure 4 is the assembly model of motor and its bracket (see Fig. 4)

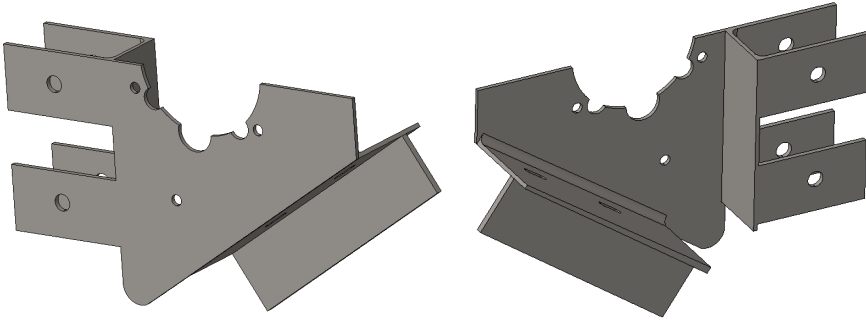

Fig. 3. Digital 3d model of electric motor bracket

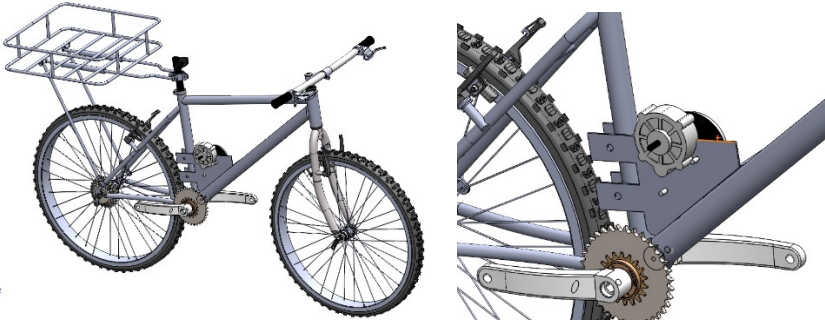

Fig. 4. Assembly model of electric motor and bracket

Bracket material is mild steel with 3 mm thickness. Table 4 is the material properties of mild steel.

Table 4. Material properties of mild steel.

Variable	Value
Mass density	7850 kg/m ³
Yield strength	250 MPa
Ultimate tensile strength	40-500 MPa
Young's modulus	200 GPa

In CAE analysis of bracket, load applied to the bracket is the maximum load received by the electric motor, which is approximately 143 kgf, or 1500 N. Determination of loads and constraints in the CAE analysis of the motor bracket is typically done based on the specific requirements and constraints of the design (see Fig. 5). The load and

constraint setup helps simulate the real-world operating conditions and ensures that the bracket can withstand the applied forces.

The results of the stress analysis and displacement analysis are typically obtained from the CAE software and are represented through stress distribution and displacement contour plots. These plots, Figure 6 and 7 respectively is visual representations of the stresses and displacements experienced by the bracket under the applied load (see Fig. 6 and Fig. 7).

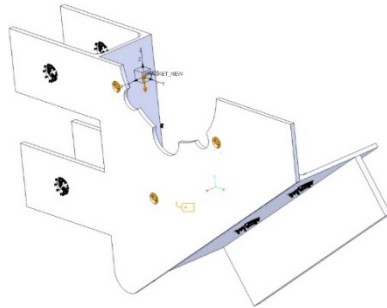

Fig. 5. Loads and constraint on bracket analysis

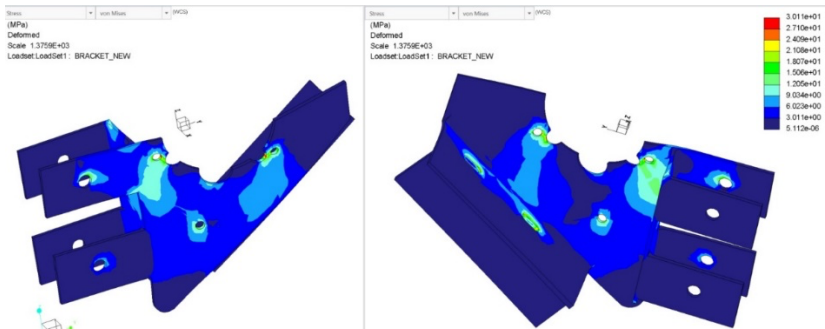

Fig. 6. Stress von-Mises analysis

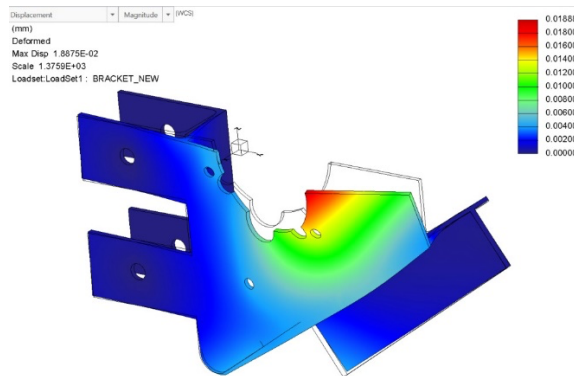

Fig. 7. Maximum displacement analysis

CAE analysis and simulation results of the electric motor bracket design are shown in table 5.

Table 5. Analysis and simulation result.

Simulation Result	Limit	Value
Stress von-Mises	Maximum	30.1 MPa
	Minimum	0 MPa
Displacement	Maximum	0.02 mm
	Minimum	0 mm

Based on the simulation results, the maximum stress obtained is 30.1 MPa, which occurs at the hole for the fastening bolt of the electric motor. This value is lower than the yield strength of the material, which is 250 MPa, considering a safety factor of 3. This indicates that the design of the bracket satisfies the engineering design criteria, as the stress experienced by the bracket is well below its yield strength.

Additionally, the maximum displacement observed in the upper bend section is relatively small, measuring only 0.02 mm. This indicates that the bracket exhibits minimal deformation under the applied load, further confirming the design's suitability.

5.4 Prototyping and Testing

Figure 8 is the prototype of mid drive e-cargo bike (see Fig. 8).



Fig. 8. Prototype of design

The prototype testing includes: testing the manual pedal mechanism and electric motor, testing the stability of the bicycle while parked and moving straight, performance testing of the electric motor, battery consumption, and mileage.

From the results of the testing on the manual pedal mechanism and electric motor, it was found that the mechanism functions properly. If cyclist wants to use the manual pedal, they can deactivate the electric motor switch and pedal as usual. When pedaling, the electric shaft does not rotate, thus not adding any load to the cyclist's pedaling effort. If they wants to use the electric motor, they can activate the electric motor

switch. Cyclist simply needs to twist the throttle on the handlebar for acceleration. When using the electric motor, the manual pedal does not rotate, allowing them to rest their feet (see Fig. 9).



Fig. 9. Manual pedal mechanism and electric motor testing

The e-cargo bike demonstrates good stability both when parked and when moving straight. This stability is maintained even when the e-cargo bike is moving straight uphill at an incline of 5 degrees (see Fig. 10). The maximum speed while traveling on a flat road range from 25 to 30 km/h. Table 6 represents the analysis results of the speed and acceleration of the e-cargo bike when passing on a flat road.



Fig. 10. Stability testing.

Table 6. Speed and acceleration on a flat road-testing result.

Vt (km/h)	Time (s)	Acceleration (m/s ²)
28.6	10	0.79
29.2	10	0.81
29.5	10	0.82

6 Conclusion

Design of mid-drive e-cargo bike can be a solution for bicycle couriers who are unable to afford an electric bike. It has a total load capacity of 143 kgf and maintains an average speed of 25 km/h on flat roads. This e-cargo bike utilizes an electric motor of the MY1016Z2 type, with a power output of 250 W and a supply voltage of 24 V. The motor operates at 3300 rpm with a gear ratio of 1:9.78. A throttle operates the control system. The bike is equipped with a LiFePO₄ battery with a specification of

24V/80Ah. The electric motor requires 200 W of power, with a current strength of 8.33 A. The maximum range of the electric bike is 240 km, and it can be used continuously for a maximum duration of 9.6 hours.

References

1. Johannes Gruber, Alexander Kihm: Barbara Lenz, A new vehicle for urban freight? An ex-ante evaluation of electric cargo bikes in courier services. *Research in Transportation Business & Management*, vol. 11, pp. 53-62 (2014)
2. Sandra Melo, Patricia Baptista: Evaluating the impacts of using cargo cycles on urban logistics: integrating traffic, environmental and operational boundaries. *Eur. Transp. Res. Rev.*, 9:30 (2017), DOI 10.1007/s12544-017-0246-8
3. Alaina Thomas: Electric bicycles and cargo bikes -Tools for parents to keep on biking in auto-centric communities? Findings from a US metropolitan area, *International Journal of Sustainable Transportation*, vol. 16 (7), pp. 637-646 (2022)
4. Lorenzo Stilo ↑, Diana Segura-Velandia, Heinz Lugo, Paul P. Conway, Andrew A. West: Electric bicycles, next generation low carbon transport systems: A survey, *Transportation Research Interdisciplinary Perspectives*, vol. 10, 100347 (2021), <https://doi.org/10.1016/j.trip.2021.100347>
5. Mariusz Nürnberg: Analysis of using cargo bikes in urban logistics on the example of Stargard, *Transportation Research Procedia* vol. 39, pp 360-369 (2019)
6. Roberto Nocerino, Alberto Colomi, Federico Lia, Alessandro Luè: E-bikes and E-scooters for smart logistics: environmental and economic sustainability in pro-E-bike Italian pilots. *Transportation Research Procedia* vol. 14, pp. 2362 – 2371 (2016)
7. Wadate P. R., Deshmukh P. S., Kadam V., Kadam T. C., Navgire M.: A Study of Electric Bike - Future Needs. *International Journal for Research in Applied Science & Engineering Technology* 2 (5), 1331-1334 (2019)
8. Abagnale C., Cardone M., Iodicea P., Marialto R., Strano S., Terzo M., Vorraro G.: Design and Development of an Innovative E-Bike. 71st Conference of the Italian Thermal Machines Engineering Association, pp 774 – 781. *Energy Procedia* 101, Turin, Italy (2016)
9. Steyn W. J., Warnich J.: Comparison of Tyre Rolling Resistance for Different Mountain Bike Tyre Diameters and Surface Conditions. *South African Journal for Research in Sport, Physical Education and Recreation* 36 (2), 179-193 (2014)
10. Valenzuela P., Mateo-March M., Muriel X., Zabala M., Lucia A., Pallares J. G., Barranco-Gil D.: Road Gradient and Cycling Power: an Observational Studyi Male Professional Cyclists. *International Journal of Science and Medicine in Sport* 25 (12), 1017-1022 (2022)
11. Malizia F., Blocken B.: Bicycle Aerodynamics: History, State-of-The-art and Future Perspectives. *International Journal of Wind Engineering & Industrial Aerodynamics* 200 (12), 104-134 (2020)
12. Blocken B., van Druenen T., Toparlar Y., Andrienne T.: CFD Analysis of an Exceptional Cyclist Sprint Position. *International Journal of Sport Engineering* 22 (10), 1-11 (2019)

Open Access This chapter is licensed under the terms of the Creative Commons Attribution-NonCommercial 4.0 International License (<http://creativecommons.org/licenses/by-nc/4.0/>), which permits any noncommercial use, sharing, adaptation, distribution and reproduction in any medium or format, as long as you give appropriate credit to the original author(s) and the source, provide a link to the Creative Commons license and indicate if changes were made.

The images or other third party material in this chapter are included in the chapter's Creative Commons license, unless indicated otherwise in a credit line to the material. If material is not included in the chapter's Creative Commons license and your intended use is not permitted by statutory regulation or exceeds the permitted use, you will need to obtain permission directly from the copyright holder.





Atlantis Highlights in Engineering
Editor-In-Chief: Zheng Zheng

Markus Hartono · Hudiyo Firmanto ·
Connie Susilawati *Editors*

Proceedings of the 4th
International Conference on
Informatics, Technology
and Engineering 2023
(InCITE 2023) · Volume 21

Series: [Atlantis Highlights in Engineering](#)

Proceedings of the 4th International Conference on Informatics, Technology and Engineering 2023 (InCITE 2023)

[HOME](#)[PREFACE](#)[ARTICLES](#)[AUTHORS](#)[SESSIONS](#)[ORGANIZERS](#)[PUBLISHING INFORMATION](#)

Editors

Markus Hartono

University of Surabaya, Surabaya, Indonesia

Hudiyo Firmanto

University of Surabaya, Surabaya, Indonesia

Connie Susilawati

Queensland University of Technology, Australia

Steering Committee

Jimmy

University of Surabaya, Surabaya, Indonesia

Organizing Committee

Agung Prayitno (Chair)

University of Surabaya, Surabaya, Indonesia

Herman Susanto (Vice Chair)

University of Surabaya, Surabaya, Indonesia

Alexander Yohan (Secretariat)

University of Surabaya, Surabaya, Indonesia

Veronica Indrawati (Treasurer)

University of Surabaya, Surabaya, Indonesia

Aloisiyus Yuli Widiyanto (Program)

University of Surabaya, Surabaya, Indonesia

Mikhael Ming Khosasih (Website and Design)

University of Surabaya, Surabaya, Indonesia

Scientific Committee

Benny Tjahjono

Coventry University, Coventry, England

Bertha Maya Sopha

Universitas Gadjah Mada, Yogyakarta, Indonesia

Hazrul Iswadi

University of Surabaya, Surabaya, Indonesia

I Made Londen Batan

Institut Teknologi Sepuluh Nopember, Surabaya, Indonesia

Itthisek Nilkhamhang

Sirindhorn International Institute of Technology, Pathum Thani, Thailand

Tan Kay Chuan

National University of Singapore, Singapore

Muhammad Rosiawan

University of Surabaya, Surabaya, Indonesia

Naniek Utami Handayani

Universitas Diponegoro, Semarang, Indonesia

Atlantis Press

Atlantis Press – now part of Springer Nature – is a professional publisher of scientific, technical & medical (STM) proceedings, journals and books. We offer world-class services, fast turnaround times and personalised communication. The proceedings and journals on our platform are Open Access and generate millions of downloads every month.

For more information, please contact us at: contact@atlantis-press.com

▶ PROCEEDINGS

▶ JOURNALS

▶ BOOKS

▶ ABOUT

▶ NEWS

▶ CONTACT

▶ POLICIES

▶ SEARCH

▶ MANAGE COOKIES/DO NOT SELL MY
INFO

[Home](#) [Privacy Policy](#) [Terms of use](#)



Copyright © 2006-2024 Atlantis Press – now part of Springer Nature

Series: [Atlantis Highlights in Engineering](#)

Proceedings of the 4th International Conference on Informatics, Technology and Engineering 2023 (InCITE 2023)

[HOME](#)[PREFACE](#)[ARTICLES](#)[AUTHORS](#)[SESSIONS](#)[ORGANIZERS](#)[PUBLISHING INFORMATION](#)[+ Advanced search](#)[SEARCH](#)

9 articles

Proceedings Article

[Designing Smart Contracts on Insurance Claims to Support the Supply Chain Performance](#)

Josephine Permata Sari, Joniarto Parung

Blockchain as a distributed ledger technology that can guarantee transparency and speed in real time is increasingly being used to increase supply chain performance directly or indirectly. Blockchain in the form of smart contracts in the insurance business will speed up insurance claims and increase...

[+ Article details](#)

[+ Download article \(PDF\)](#)

Proceedings Article

The Adoption of the Response Surface Methodology within the DMAIC Process to Achieve Optimal Solutions in Reducing Product Defect

Yenny Sari, Amelia Santoso, Nadia Angelina Putri Pangestu

The high number of defective products can cause the company to receive many complaints. This research aimed to apply the quality improvement approach i.e., the DMAIC methodology (Define-Measure-Analysis-Improve-Control), to reduce product defect. The object of discussion was the black-color cloth hangers...

[+ Article details](#)

[+ Download article \(PDF\)](#)

Proceedings Article

The Interaction Effect of CaCO₃ Composition, Injection Temperature, and Injection Pressure on the Tensile Strength and Hardness of Recycled HDPE

Hendra Prasetyo, Yon Haryono, The Jaya Suteja

The mechanical properties of recycled High-Density Polyethylene (HDPE) are inferior compared to non-recycled HDPE. To overcome this problem, Calcium Carbonate (CaCO₃) is added to improve the material's mechanical properties. The temperature and injection pressure changes can affect the

material's mechanical...

[+ Article details](#)

[+ Download article \(PDF\)](#)

Proceedings Article

Comparing the Effects of Efficiency and Distortion in Audio Power Amplifiers with and without Tracking Power Supply Circuit Design

Yohanes Gunawan Yusuf, Veronica Indrawati

This research aims to compare the effects of efficiency and distortion in Audio Power Amplifiers with and without Tracking Power Supply (TPS) circuit design. The TPS circuit design is known for enhancing power efficiency while keeping low distortion in the amplifiers. This paper examined the performance...

[+ Article details](#)

[+ Download article \(PDF\)](#)

Proceedings Article

Restructuring Job Design Using Job Analysis to Balance Workload and Enhance Productivity

Revy Maghriza, Moses Laksono Singgih

One logistics company in Indonesia has experienced a drastic increase of 60% in the demand for imported goods from 2018 to 2022. This upward trend is expected to continue. The admin staff, leader, and supervisor of the Export-Import Department feel the direct impact and are experiencing a higher workload...

[+ Article details](#)

[+ Download article \(PDF\)](#)

Proceedings Article

Design of Mid Drive Electric Cargo Bike for Urban Area

Sunardi Tjandra, Susila Candra, Albertus Agung Jody Saputra, Yehezkiel D. Faraisc Putra

Some couriers use bicycles for work. However, it is not efficient because relies on their stamina, which can affect the delivery duration and capacity. E-bike can be a solution to this problem. However, its price is unaffordable for most couriers. It is necessary to modify the couriers' bicycles into...

[+ Article details](#)

[+ Download article \(PDF\)](#)

Proceedings Article

Affective-based Human Factors Design: Design Thinking & Sustainability Approach

Markus Hartono

This paper proposes a refined framework of affect/Kansei-based applied to product/service experience considering design thinking and sustainability approaches. Design thinking facilitates more comprehensive step-by-step methodology starting with more human basic needs, followed by the global issues which...

[+ Article details](#)

[+ Download article \(PDF\)](#)

Proceedings Article

Has Website Design using Website Builder Fulfilled Usability Aspects? A Study Case of Three Website Builders

Argo Hadi Kusumo

The significance of e-commerce is particularly crucial for businesses. The

enhancement of sales can be achieved through the contribution of e-commerce. In the current era of digitalization, it is unnecessary for SMEs to develop e-commerce platforms from scratch. Instead, they can opt for affordable website...

[+ Article details](#)

[+ Download article \(PDF\)](#)

Proceedings Article

Design of Employee Bus Routes for Madiun City Government Based on Home Locations and Presence Location History

Daniel Hary Prasetyo, Arizia Aulia Aziiza, Endang Sulistiyani

Madiun City is strategically positioned as the center of regional activities in the western part of East Java Province. Based on the data presented for the City of Madiun in Figures for 2022, the number of residents and private vehicle units is almost the same. Hence, road congestion is likely to occur...

[+ Article details](#)

[+ Download article \(PDF\)](#)

Atlantis Press

Atlantis Press – now part of Springer Nature – is a professional publisher of scientific, technical & medical (STM) proceedings, journals and books. We offer world-class services, fast turnaround times and personalised communication. The proceedings and journals on our platform are Open Access and generate millions of downloads every month.

For more information, please contact us at: contact@atlantis-press.com

- ▶ JOURNALS
- ▶ BOOKS
- ▶ POLICIES
- ▶ MANAGE COOKIES/DO NOT SELL MY INFO
- ▶ NEWS
- ▶ CONTACT
- ▶ SEARCH

[Home](#) [Privacy Policy](#) [Terms of use](#)



Copyright © 2006-2024 Atlantis Press – now part of Springer Nature