

## THE EFFECT OF BRAND IMAGE ELEMENTS ON PRICE PREMIUM AND BRAND LOYALTY OF SAMYANG BRAND INSTANT NOODLE IN SURABAYA

**Ing Erviana**

Faculty of Business and Economic, Universitas Surabaya  
iceprincessevi@gmail.com

**Dudi Anandya**

Faculty of Business and Economic, Universitas Surabaya  
samkidud@gmail.com

**Indarini**

Faculty of Business and Economic, Universitas Surabaya  
Indarini2003@yahoo.com

### *Abstract*

*This study aims to examine the positive relationship between elements of brand image namely brand awareness, perceived quality, uniqueness, CSR, social image, and country of origin on price premium and brand loyalty for the purchase of Samyang brand instant noodle in Surabaya. The results of this study indicated that brand awareness, perceived quality, and country of origin had no significant effect on price premium and brand loyalty while social image and uniqueness had a positive effect on price premium and brand loyalty so that only social image and uniqueness variables affect price premium and brand loyalty. The distribution manager of Samyang brand instant noodle in Indonesia needs to focus on social image and uniqueness variables and ignore the variables of brand awareness, perceived quality, and country of origin to get price premium and brand loyalty.*

**Keywords:** brand awareness, perceived quality, country of origin, social image, uniqueness.

### *Abstrak*

*Penelitian ini bertujuan untuk menguji hubungan positif antara elemen-elemen brand image yaitu brand awareness, perceived quality, uniqueness, CSR, Social image, dan country-of-origin terhadap price premium dan brand loyalty atas pembelian mi instan merek Samyang di Surabaya. Hasil penelitian ini menunjukkan bahwa brand awareness, perceived quality, dan country of origin tidak berpengaruh signifikan pada price premium dan brand loyalty sementara social image dan uniqueness berpengaruh positif pada price premium dan brand loyalty sehingga hanya variabel social image dan uniqueness yang berpengaruh pada price premium dan brand loyalty. Manajer distribusi mi instan merek Samyang di Indonesia perlu fokus pada variabel social image dan uniqueness serta mengabaikan variabel brand awareness, perceived quality, dan country of origin untuk mendapatkan price premium dan brand loyalty.*

**Kata Kunci:** brand awareness, perceived quality, country of origin, social image, uniqueness.

JEL: M31

## **1. Research Background**

Research results from Bain and Company (2012) and International Enterprise Singapore (2013) found that Indonesian consumers are willing to pay price premiums for functional or useful products that are able to give them social status. This phenomenon found in Indonesia is similar to the phenomenon found by Anselmsson et al. (2014). Anselmsson et al. (2014) found that elements of brand image namely brand awareness, perceived quality, corporate social responsibility (CSR), country of origin, social image, and uniqueness has a positive effect on price premium and brand loyalty. Anselmsson et al. (2014) stated that brand awareness has an effect on brand loyalty, but the results of research from Cho (2011) showed that brand awareness does not have a significant effect on brand loyalty. The research from Cho has the same results as the research from Subhani and Osman (2010) who found that there is no relationship between brand awareness and brand loyalty in the packaged milk beverage industry in Pakistan. This Subhani and Osman study divides brand awareness variables into 2 stages, namely brand recall and brand recognition. In testing the effect of brand awareness on brand loyalty, brand loyalty was represented by one of its characteristics, namely repeated purchase.

Yuen and Chan (2010) also have different opinions with Anselmsson et al. (2014). Yuen and Chan pinpointed that perceived quality has no effect on customer loyalty. Yuen and Chan's research was in a retail fashion store to test the effect of retail service quality and product quality dimensions. On the other hand, Long et al. (2013) also concluded that perceived quality has a negative effect on customer loyalty.

Anselmsson et al. (2014) previously also stated that perceived quality and uniqueness has a positive effect on brand loyalty but the results of research from Kinuthia et al. (2012) showed different opinions. Kinuthia et al. (2012) conducted a study in Nairobi, Kenya in order to examine the variables that allegedly influence brand loyalty. The results were price and variety, brand uniqueness; attractiveness, ads and product quality, and size and brand reputation have no effect on the brand loyalty of swimwear worn by swimmer students at Kenyan University.

In addition, there was also a study by Andreani et al. (2012) from Universitas Kristen Petra who also found that the uniqueness of brand association has no effect on customer loyalty. The research by Andreani et al. (2012) was done in Surabaya with McDonald's fast food restaurant as the object of their research.

Zilaie et al. (2016) research results were also different from Anselmsson et al. (2014) research results which stated that the country of origin influences brand loyalty. Zilaie et al. (2016) divided the country of origin variable into the cognitive and affective country image, and brand loyalty variables into attitudinal and behavioral brand loyalty. The results found that the hypothesis about the influence of cognitive country image on attitudinal brand loyalty was not supported.

Research from Loureiro and Umberger (2004) also refuted the study results of Anselmsson et al. (2014) which stated that country of origin has an effect on price premium. Loureiro and Umberger (2004) concluded that only 30% of respondents are willing to pay price premiums for beef and pork products with the U.S Certified label because the majority of beef and pork products in the U.S have been labeled the U.S Certified. Similarly, research from Chen et al. (2011) with the object of research in the form of tool products found that country of origin does not affect brand equity while according to Aaker (1991, 1996) in Anselmsson et al. (2007), brand loyalty is one of the 4 dimensions in brand equity. This then leads to the assumption that country of origin does not affect brand loyalty.

Anselmsson et al. (2014) study was also previously replicated by Murad and Ali (2015) who found that brand awareness, perceived quality, social image, and uniqueness have no effect on consumers' willingness to pay price premium. The variable that influences the willingness to pay price premium in his research was country of origin. The debate over the

results of the above researcher is interesting to be retested to prove the variables that support or weaken price premium and brand loyalty to a consumer good brand.

In 2013, the results of the International Enterprise Singapore survey showed that Indonesian consumers carried out the largest consumption (41.7%) for non-alcoholic food and beverage products. It can be seen that dried processed foods have the largest percentage of 33%, followed by bread products with a percentage of 15% and the third place occupied by dairy products with a percentage of 11%. Similar results from the Food Information Council Foundation (2010) and survey results from Agriculture and Agri-food Canada (2014) summarized the sales of each category of agricultural food in Indonesia in 2013. Based on the results of the survey, it was found that the packaged food category has total sales of US \$ 29,990.6 million with the highest sales was contributed by dried processed food which amounted to US \$ 8,980.1 million.

This study conducted a poll in Surabaya with respondents of the community residing in Surabaya. Respondents who were asked to fill out a poll must understand the definition of in-pack dry processed food and price premium. Respondents were then asked to choose one of the in-pack dry processed food categories that is most often purchased from the available categories of instant noodles, pasta, breakfast cereals, butter, and cheese. In addition, respondents can also fill in frequently purchased in-pack dry processed food categories that outside the available categories, under “other” option. Here are the results of the poll.

**Table 1. In-Pack dry processed foods polling category**

The most frequently purchased in-pack dry processed foods category	Frequency	Percentage (%)
Instant noodle	21	70
Pasta	0	0
Breakfast cereal	4	13.33
Butter	3	10
Cheese	2	6.67
Others	0	0
Total	30	100

Source: Polling results September 29 – October 5, 2016, processed

It can be seen from the results of the poll in table 1 that the most frequently purchased in-pack dry processed food with the price premium category is instant noodles with 70%. The results of this poll are strengthened by the results of a survey by the World Instant Noodles Association (WINA) which found that Indonesia with a consumption rate of 14,900 million packs of instant noodles in 2013 was the second largest consuming country for instant noodles in the world. The first rank was occupied by the People's Republic of China (PRC) which consumed 46,220 instant noodles in 2013 (Source: <https://info-kesehatan.net/indonesia-pemakan-mi-instan-kedua-terbanyak/>). In addition, the poll results also show the brand of instant noodles with price premium that was most often purchased by the respondent. An open option was carried out for this poll which allows respondents can freely fill the brand of instant noodles with price premium that they buy most often.

**Table 2. Polling results for the most frequently purchased instant noodle brand with price premium**

Instant noodle brand	Frequency	Percentage (%)
Samyang	13	61.9
Sutah	1	4.761
Paldo	1	4.761
Ottogi	2	9.523
Nong Shim	1	4.761
Shin Ramyun	2	9.523
Nissin	1	4.761
Total	21	100

Source: Polling results September 29 – October 5, 2016, processed

Based on the pool results in table 2, it can be seen that the most frequently purchased price premium instant noodle brand by respondents is Samyang with a percentage of 61.9%. The results of this poll are reinforced by sales data of a mobile marketplace in Indonesia, Elevenia, which showed that the Samyang sale and purchase transaction on its site reached 9,210 packs daily even though the selling price is much higher than other Korean instant noodles. The Korea Tourism Organization said that the high enthusiasm for Samyang brand instant noodle is caused by the Korean wave or South Korean culture that is widespread in Indonesia and also because of Samyang brand offering a spicy taste that is favored by the majority of Indonesians (cnnindonesia 2016). In addition, Samyang brand instant noodle is also one of the five popular foods in Indonesia by AntaraNews. The popularity of Samyang brand instant noodle in Indonesia originated from the bustling Samyang challenge on YouTube. (antaranews 2016). Thus, this is the reason for using Samyang brand instant noodle as the object of this study to test the Murad and Ali (2015) research model.

There are several problems in this study: (1a) Does brand awareness affect the willingness of consumers to pay price premium for Samyang brand instant noodle in Surabaya? (1b) Does brand awareness affect brand loyalty of Samyang brand instant noodle in Surabaya? (2a) Does the perceived quality affect the willingness of consumers to pay price premium for Samyang brand instant noodle in Surabaya? (2b) Does perceived quality affect the brand loyalty of Samyang brand instant noodle in Surabaya? (3a) Does the country of origin affect the willingness of consumers to pay price premium for Samyang brand instant noodle in Surabaya? (3b) Does the country of origin affect the brand loyalty of Samyang brand instant noodle in Surabaya? (4a) Does social image affect the willingness of consumers to pay the price premium for Samyang instant noodle in Surabaya? (4b) Does social image influence the brand loyalty of Samyang brand instant noodle in Surabaya? (5a) Does uniqueness affects the willingness of consumers to pay price premium for Samyang brand instant noodle in Surabaya? (5b) Does uniqueness affects the brand loyalty of Samyang brand instant noodle in Surabaya?

The problems found in this study then produce research objectives, namely; (1) Analyzing the influence of brand awareness, perceived quality, country of origin, social image, and uniqueness on consumers' willingness to pay price premium for Samyang brand instant noodle in Surabaya and (2) Analyzing the influence of brand awareness, perceived quality, country of origin, social image, and uniqueness on brand loyalty of Samyang brand instant noodle in Surabaya.

## 2. Research Method

This research is categorized as basic research and referred to as causal research because this study aims to prove the influence of brand image on price premium and brand loyalty through elements of brand image namely brand awareness, perceived quality, country of origin, social image, and uniqueness on Samyang brand instant noodle products in Surabaya. The approach in this study was included in the quantitative approach. The data sources used in this study were primary data through a research instrument in the form of a questionnaire. The questionnaire used interval scales arranged into 1-5 numerical scale.

The questionnaire was distributed to a sample of the target population of this study. The target population in this study was respondents who had bought and consumed Samyang brand instant noodle products in Surabaya. Population characteristics were respondents who are domiciled in Surabaya; respondents who have purchased and consumed Samyang brand instant noodle products at least 3 times over the past 3 months; respondents who knew that Samyang brand instant noodle is a product with a price premium or higher price than other similar products; and respondents who have at least high school education level because the education level will enable respondents to understand the statements given in the questionnaire. The sample used was 237 out of 250 respondents who had bought and consumed Samyang brand instant noodle products in Surabaya for the past 3 months. In taking sampling, this study used a non-probability sampling method.

Data processing in this study used the Structural Equation Modeling (SEM) analysis model with Lisrel 8.7 software. Tests carried out on the statements in the questionnaire were validity testing using internal consistency, namely the Pearson product-moment method, reliability testing, and Structural Equation Modeling (SEM) test. This SEM test consists of five tests of the Goodness of Fit (GOF) conformity index in the form of absolute and incremental measurements in conformity testing of the following models, namely CMIN / DF (Relative Chi-Square), GFI (Goodness of Fit Index), RMSEA (The Root Mean Square Error of Approximation), NNFI (Non-Normed Fit Index), and CFI (Comparative Fit Index).

After the Goodness of Fit (GOF) test has been conducted, the next step was testing the hypothesis by looking at the structural model in SEM. This study used an error rate of  $\alpha$  of 5% so that the hypothesis will be accepted when  $t\text{-value} \geq 1.96$ . Through testing this hypothesis, it can be known whether the proposed hypothesis is supported or not. The next step was to test the validity and reliability of composite reliability and extracted variance.

$$\text{Construct Reliability} = \frac{(\sum \text{standardized loading})^2}{(\sum \text{standardized loading})^2 + \sum e_j}$$

$$\text{Variance extracted} = \frac{\sum (\text{standardized loading})^2}{\sum (\text{standardized loading})^2 + \sum e_j}$$

## 3. Result and Discussion

The results of data processing in the form of a measurement model from Lisrel 8.7 obtained from respondents' responses are as follows:

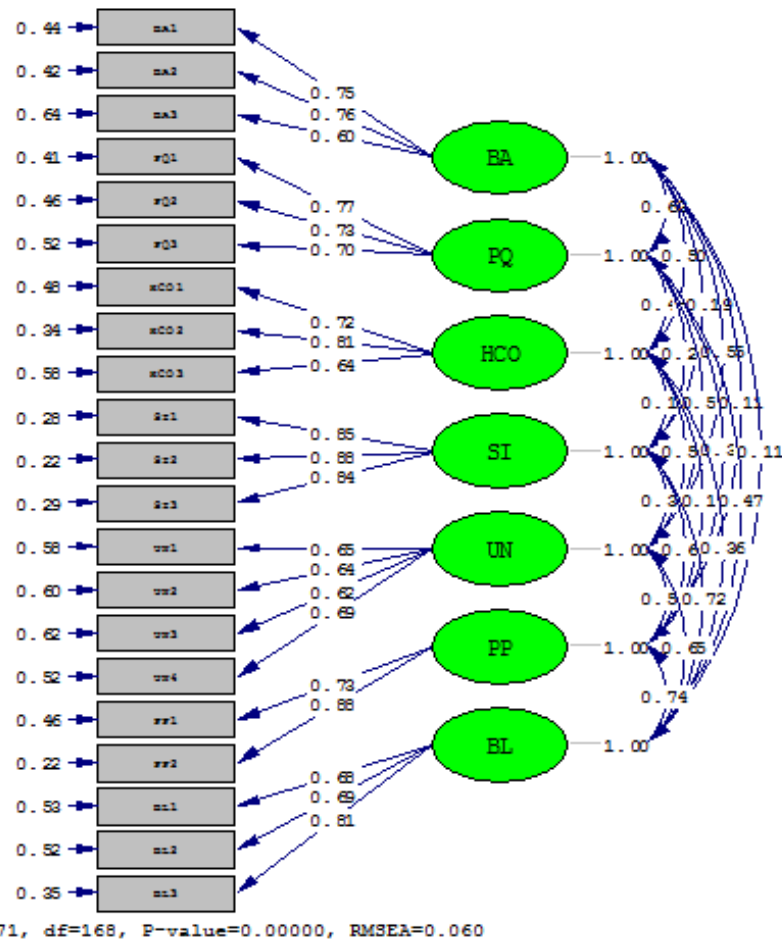

Source: Lisrel 8.7 Data processing

**Figure 1. Lisrel measurement model**

The measurement model processed by LISREL 8.7 above shows that all indicators had a standard loading value > 0.5. This shows that the model is suitable to be the measurement model in this study. The following is a table that describes the results of the compatibility test processed by the LISREL 8.7 software.

**Table 3. Results of compatibility test on measurement model**

No.	Compatibility Test	Compatibility Criteria	Result	Description
1.	CMIN/DF	CMIN/DF ≤ 3	1.85	Good Fit
2.	GFI	GFI ≥ 0.90	0.89	Marginal Fit
3.	RMSEA	RMSEA 0.03-0.08	0.06	Good Fit
4.	NNFI	NNFI ≥ 0.95	0.96	Good Fit
5.	CFI	CFI ≥ 0.95	0.97	Good Fit

Source: Results of data processing by Lisrel 8.7.

It can be seen from table 3 that the GOF test results of this study are good. In addition, the standardized loading value of each research indicator was also valid as shown in table 4 below:

**Table 4. Results of validity testing on measurement model**

Variable	Variable Indicator	Standardized Loading ( $\lambda$ )	Description
Brand Awareness	BA1	0.72	Valid
	BA2	0.78	
	BA3	0.61	
Perceived Quality	PQ1	0.76	Valid
	PQ2	0.72	
	PQ3	0.71	
Country of origin	HCO1	0.72	Valid
	HCO2	0.82	
	HCO3	0.65	
Social Image	SI1	0.85	Valid
	SI2	0.88	
	SI3	0.84	
Uniqueness	UN1	0.65	Valid
	UN2	0.64	
	UN3	0.62	
	UN4	0.69	
Price premium	PP1	0.73	Valid
	PP2	0.88	
Brand Loyalty	BL1	0.68	Valid
	BL2	0.69	
	BL3	0.81	

Source: Results of data processing by Lisrel 8.7.

All variables in this study were also declared valid and reliable as shown in the following Tables 5 and 6:

**Table 5. Variance Extracted**

Variable	$\sum \text{std.loading}^2$	$\sum \text{error}$	Variance Extracted
BA	2.51	0.89	0.74
PQ	2.57	0.80	0.88
HCO	2.55	0.83	0.75
SI	2.78	0.43	0.86
UN	3.22	1.4	0.70
PP	1.79	0.39	0.82
BL	2.55	0.82	0.76

Source: Excel 2013, processed.

**Table 6. Construct Reliability**

Variable	$(\sum \text{std.loading})^2$	$\sum \text{error}$	Construct Reliability
BA	4.45	0.89	0.83
PQ	4.84	0.80	0.86
HCO	4.71	0.83	0.85
SI	6.60	0.43	0.94
UN	6.76	1.4	0.83
PP	2.59	0.39	0.87
BL	4.75	0.82	0.85

Source: Excel 2013, processed.

This study then also tested the GOF on the structural model of this study and can be seen in table 7 below.

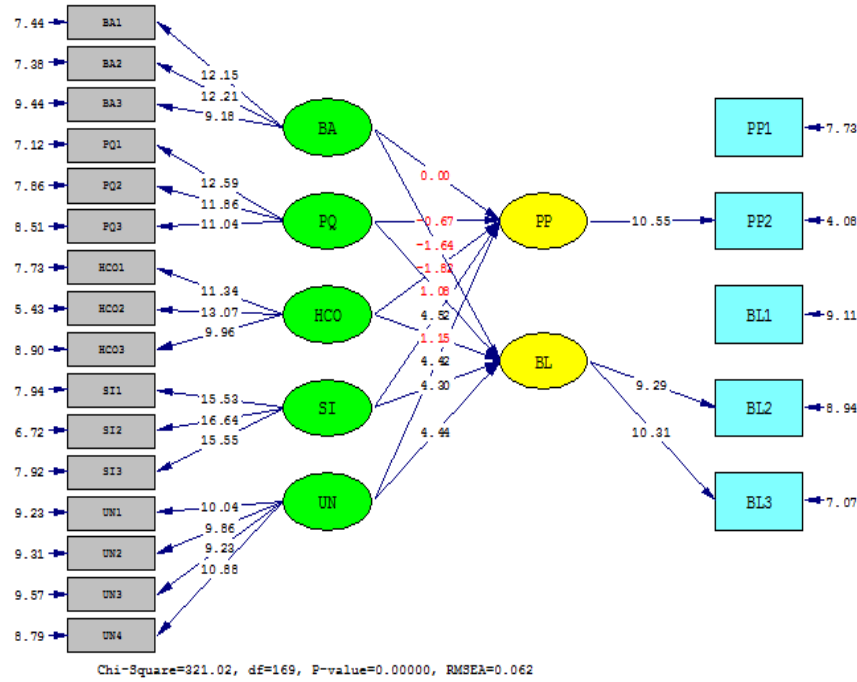

Source: Data processing by Lisrel 8.7

**Figure 2. Lisrel Structural Model**

Figure 2 shows the structural model in this study while Table 7 shows that the GOF test on the structural model has a good match level.

**Table 7. Results of Structural Model Compatibility Testing**

No.	Compatibility Test	Compatibility Criteria	Result	Description
1.	CMIN/DF	CMIN/DF $\leq$ 3	1.9	Good Fit
2.	GFI	GFI $\geq$ 0.90	0.89	Marginal Fit
3.	RMSEA	RMSEA 0.03-0.08	0.06	Good Fit
4.	NNFI	NNFI $\geq$ 0.95	0.96	Good Fit
5.	CFI	CFI $\geq$ 0.95	0.97	Good Fit

Source: Results of data processing by Lisrel 8.7.

The conclusions obtained from the structural model of this research are described in Table 8. From Table 8, it can be seen that hypotheses 4a, 4b, 5a, and 5b had t-values  $\geq$  1.96 which indicate that the hypotheses are supported while hypotheses 1a, 1b, 2a, 2b, 3a, and 3b were not supported because t-values  $\leq$  1.96. The results of this study were then summarized in the research model as shown in the following figure.



**Table 8 Evaluation of Structural Models and their Relation to Research Hypotheses**

Hypothesis	Path	Standardized Estimates	t-values	Description
H1a	BA → PP	0.0	0.00	Not Significant (Hypothesis not supported)
H1b	BA → BL	-0.23	-1.64	Not Significant (Hypothesis not supported)
H2a	PQ → PP	-0.08	-0.67	Not Significant (Hypothesis not supported)
H2b	PQ → BL	0.12	1.08	Not Significant (Hypothesis not supported)
H3a	HCO → PP	-0.16	-1.82	Not Significant (Hypothesis not supported)
H3b	HCO → BL	0.09	1.15	Not Significant (Hypothesis not supported)
H4a	SI → PP	0.49	4.52	Significant (Hypothesis supported )
H4b	SI → BL	0.44	4.30	Significant (Hypothesis supported )
H5a	UN → PP	0.57	4.42	Significant (Hypothesis supported )
H5b	UN → BL	0.54	4.44	Significant (Hypothesis supported )

Source: Data processing by Lisrel 8.7

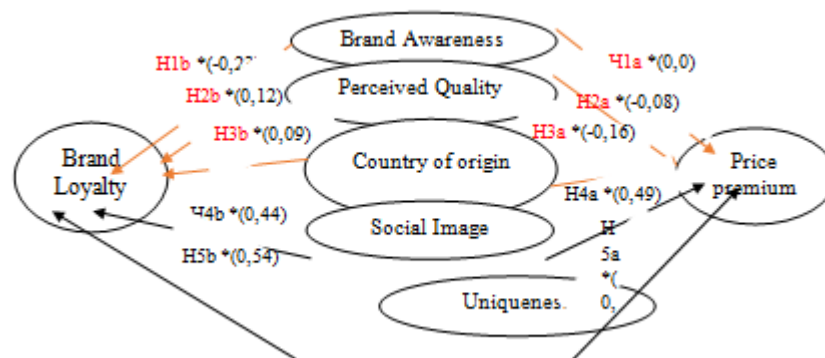

Source: Lisrel 8.7, processed

**Figure 3. Results of Research Model**

#### 4. Conclusion

The conclusions that can be obtained from this study are: first, brand awareness, perceived quality, and country of origin had no significant positive effect on price premium and second, social image and uniqueness had a significant positive effect on price premium and brand loyalty. Respondents in Surabaya did not pay too much attention on brand awareness, perceived quality, and country of origin in buying Samyang brand instant noodle. Respondents tended to pay attention to the social image and uniqueness factors of Samyang brand instant noodle which can affect price premium and brand loyalty.

Recommendation for further research is that further research should also consider the society culture variable as part of the research model, the relationship between brand awareness and perceived quality on price premium in the research model needs to be reviewed because

both this study and Murad and Ali's study (2015) with similar research models found that brand awareness and perceived quality did not affect price premium. Moreover, further research can expand the object of research into other food categories, chose the object of research that had CSR activities in Indonesia so that CSR variables can be included in the study, and use larger samples or carried out in other areas, so that it can cover a wider population and better reflect the actual situation.

Some suggestions for the distribution manager of Samyang brand instant noodle in Indonesia are that managers need to focus on social image and uniqueness by advertising Samyang brand instant noodle on Indonesian television channels by using Korean artist advertising stars favored by many Indonesians such as Song Joong Ki, Song Hye Kyo, EXO, and Girls' Generation, make videos on YouTube, as well as conduct cooking competitions with the theme of Indonesian specialties with the main ingredients of Samyang brand instant noodles. Managers can also ignore brand awareness, perceived quality, and country of origin by reducing marketing implementation such as Samyang challenges and discounts in retails.

## References

- Agriculture, Agri-food Canada. 2014. *Market Overview Indonesia*. Canada.
- Andreani F, Lucy T, Natalia MPR. 2012. The Impact of Brand Image, Customer Loyalty with Customer Satisfaction as A Mediator in Mcdonald's. *Journal of Management and Entrepreneurship*. 14(1): 63–70.
- Anselmsson J, Johansson U, Persson N. 2007. Understanding price premium for grocery products: a conceptual model of customer-based brand equity. *Journal of Product & Brand Management*. 16(6): 401 - 414.
- Anselmsson J, Bondesson N, Johansson U. 2014. Brand image and customers' willingness to pay a price premium for food brands. *Journal of Product & Brand Management*. 23(2): 90 - 102.
- Antaranews [internet]. 2016. [Cited in 2017 January 20]. Available from <http://www.antaranews.com/berita/602370/lima-makanan-populer-diindonesia-versi-2016>
- Chen Y, Su Y, Jyh Lin F. 2011. Country-of-Origin Effects and Antecedents of Industrial Brand Equity. *Journal of Business Research*. 1234-1238.
- Cho E. 2011. Development of a brand image scale and the impact of lovemarks on brand equity. [Thesis] USA: Iowa State University.
- CNNIndonesia [internet]. 2016. [Cited in 2017 January 20]. Available from <http://www.cnnindonesia.com/gaya-hidup/20161015060604-262165660/dalam-sehari-9210-bungkus-mi-samyang-terjual-diindonesia/>
- Kinuthia LN, Mburugu KG, Muthomi HN, Mwihak M. 2012. Factors Influencing Brand Loyalty in Sportswear among Kenyan University Students: The Case of Swimmers. *Asian Journal of Social Sciences & Humanities*. 1(4).
- Long S. 2013. Sustaining Customer's Loyalty: A Survey of a Coating Resins Manufacturer. *Journal of Scientific and Industrial Research*. 72: 731-734.
- Loureiro ML, Umberger WJ. 2004. A Choice Experiment Model For Beef Attributes: What Consumer Preferences Tell Us. *Journal of Agricultural and Applied Economics*. 37(1): 49-63.
- Mabiso, A. 2005. Estimating Consumers' Willingness-to-Pay for Country-of-Origin Labels in Fresh Apples and Tomatoes: a Double-Hurdle Profit Analysis of U.S. Data Using Factor Scores. [Thesis]. USA: University of Florida.
- Murad S, Ali M. 2015. An Empirical Study on Brand Image and Customers' Willingness to Pay a Price Premium for Packaged Food Brands. *Kuwait Chapter of Arabian Journal of Business and Management Review*. 5(1).
- Subhani MI, Osman A. 2009. A Study On The Association Between Brand Awareness And

Consumer/Brand Loyalty For The Packaged Milk Industry In Pakistan. *Munich Personal RePEc Archive*.

Yuen EFT, Chan SSL. 2010. The effect of retail service quality and product quality on customer loyalty. *Database Marketing & Customer Strategy Management*. 17(3/4): 222–240.

Zilaie R, Kordnaeij A, Ahmadi P. 2016. The Relative Contribution of Brand Love and Country Image towards the Formation of Brand Equity. *Mediterranean Journal of Social Sciences*. 7(2): S2.